

A photograph of astronaut Steve MacLean in a white spacesuit, floating in space. He is positioned vertically, with his head at the bottom and feet at the top. The background is a clear blue sky. The text is overlaid on the image.

A Small Balloon/Satellite Platform for Space Science Research

Yunlong Lin

with his team
at

York University

Outline

1 Research Area and Experience

YES Program, EDSat, QuickSat ...

Spectrum of Small Satellites

2 Concurrent Engineering

3 40s Small Balloon/Satellite Platform:

40kg, 40Watts, 40Km, 40days

4 Key technologies development for Space Science

Missions

5 Space Science Package and scientific Applications

6 Summary

Research Area

- ❖ **The Engineering in Space Systems Development**
 - **Space Systems C.D.I.O. Cycle and Systems Engineering Approach**
 - **Systems Engineering and Management in Smallsat Development**
 - **Production Reliability, Quality Assurance and Safety Assessment**
 - **Concurrent Design System**
 - **Designing & Prototyping Smallsat OBDH: MIL-STD-1553B Bus**
 - **Smallsat Development (Double Star Project)**

- ❖ **Research in the Space Environment and its Effects**
 - **Characterizing Space Environment and Environmental Effects**
 - **Monitoring, Testing, Simulation, Protection and Mitigation**
 - **Practices in Protection of Satellite and its Materials from Space Environment**

- ❖ **Space Optical Instrumentation**
 - **Instrument Development for Spatial Heterodyne Observations of Water**
 - **Contamination Monitor for Space Optical Material Performance Research**

1. The Engineering in Space Systems Development

1.1 Space Systems C.D.I.O. Cycle and Systems Engineering Approach

What is C.D.I.O. Cycle?

= Create Directory, Input, Output

= Conception, Design, Implementation and Operation
Space System Life Cycle

What is System Engineering?

INCOSE: Systems Engineering is the "people-oriented engineering profession". Systems Engineers determine the most effective ways for an organization to use all of a given system's components -- people, machines, materials, information, and energy. Systems engineers plan, design, implement and manage complex systems that assure performance, safety, reliability, maintainability at reasonable cost and delivered on time.

Systems Engineering Approach: **Top Down model**

Systems Engineering is concerned with the effective design, production, deployment, operation, maintenance, refinement, and retirement of reliable systems within **cost and time** constraints.

Systems Engineering applies an appropriate combination of theories and tools, carried out through the use of a suitable methodology and a set of system management procedures, to address real world problems that are often of large scale and scope.

Systems engineering activities vary from requirements definition or specification to the conceptual and functional development of systems.

Systems engineer takes a "**top down**" perspective dealing with details only as needed to guarantee successful implementation. Whereas the product engineer deals with system internals, the systems engineer also addresses the external view of the system through the system's **interface** to other systems, users, and managers.

The Vee Model - The Vee Model addresses the technical aspect of the project cycle and represents the sequence of project events.

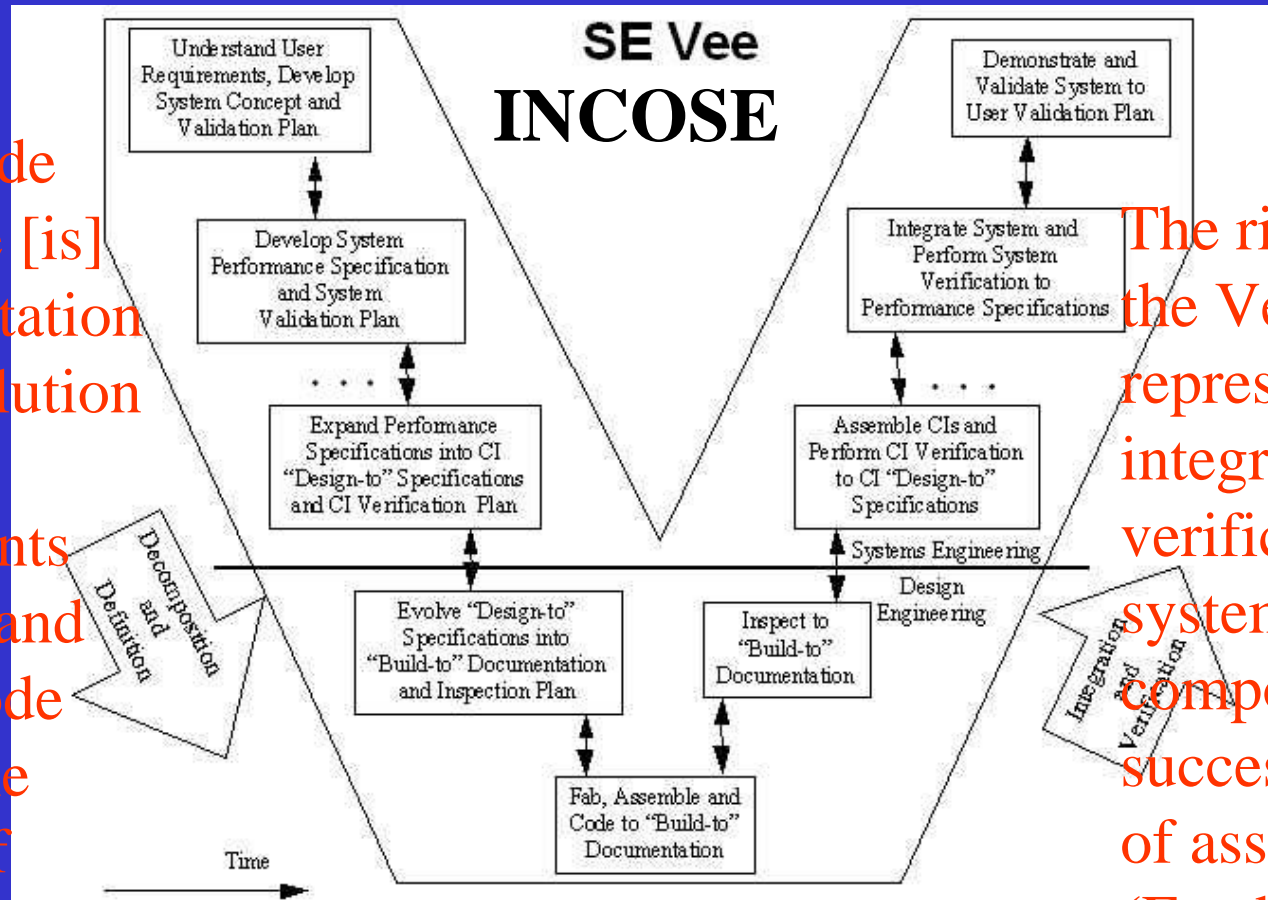

The left side of the Vee [is] a representation of the evolution of user requirements into parts and lines of code through the process of decomposition and definition.

The right side of the Vee represents the integration and verification of the system components into successive levels of assembly. (Forsberg, 1992, 1995)

Applying SE in SE (Systems Engineering in Space Engineering):

Top Down modelling of ISO/IEC 15288, Manage the Processes to become more efficient and cost-effective

Goal: To create an understanding of the complete environment and dependencies. To define interactions between processes and activities.

Output: a dynamic model of ISO 15288 down to activity level, including inputs, outputs and methods, long term tools, personnel and controls.

Applying ISO 9001: 2000 (1998) Quality Management Certification System in Space Engineering:

- Principle: Customer focus

- Leadership
- Processes approach
- Continual improvement making
- Mutually beneficial supplier relationships
- Involvement of people
- System approach to management
- Factual approach to decision

1.2 Systems Engineering and Management in Smallsat Development

State-of-the-art system engineering methodologies, design techniques, tools, processes, and training are applied to reduce the time and cost, and improve the quality of smallsat development.

The philosophy of “*affordable access to space*” in the small satellite categories is applied to all aspects of design, procurement, construction, test, launch and operation as well as tackling the project management in a unique way.

- Create a flexible management structure
- Maintain a small organization with the key innovative members
- Personal responsibility for quality and risk assessment
- Good inter-team communication
- Technically skilled project management.

- A vertically integrated system were setup, thus not to have to rely totally on sub-contractors while also being able to maintain a close watch on quality.
- Implement International Organization for Standardization (ISO)'s aerospace total quality management systems (ISO9000/AS9100 family).
- A 'one vote' Production Assurance (PA) Manager take an overseeing responsibility to ensure a PA plan is followed.
- Space standard, norms and database are applied in all the phases of simulation, integration and test.
- On the technical side, driven by design-to-cost-and-schedule, apply COTS components by means of layered redundancy and systematic hardening in smallsat engineering.
- All the new technologies are flight-tested.
- The **interface standards** (mechanical, electrical and data systems)
- **Modularity** on smallsat platform.

1.3 Production Reliability, Quality Assurance and Safety Assessment

Multi-disciplinary methods, tools, and processes including modeling and simulation will be used to define the smallsat architecture to improve performance, risk management, safety, reliability, testability, quality, efficiency and flexibility of application.

1.4 Concurrent Design System

Concurrent Design System is one of most effective practices and methodologies to enable actual smallsat engineering. It is an **Integration Design Environment (IDE)** opened to multi-disciplinary designers and users for interdisciplinary and inter-directorate applications, based on **Concurrent Engineering Methodology**.

The facility contains extensive simulation and computing resources with industry standard software and hardware for the application of the integrated design tools, project data, mission and system models. CDS can execute all the smallsat sub-system level and system level designs and simulations, based on integration of high-end software tools.

The team orientated design system allows simultaneous participation of all mission domains including Programmatic/AIV, operations, cost assessment, risk analysis, CAD and simulation. The design system is a “collaborative, co-operative, collective” system that can support all perspectives in parallel throughout the product life cycle, and is an essential tool for mission evaluation, decision-making and risk management.

Concurrent Engineering for Space Mission Development and Spacecraft Design and Implementation

Design process

Mission requirements & constraints

Objectives
Environment
Lifetime
Payload
Reliability
Schedule
Technology
Budget

Study requirements

Products
Study Level
Planning
Resources

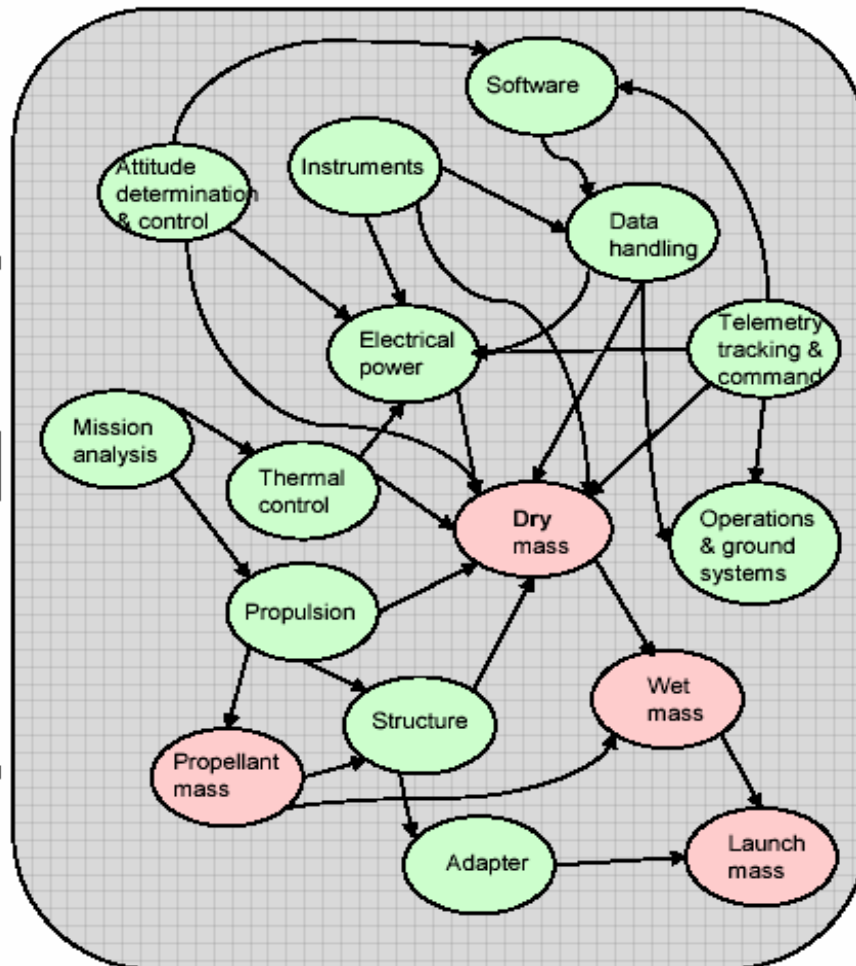

Study results

S/C Design
S/C Configuration
Launcher
Risk
Cost
Simulation
Programmatics
Options

Conceptual model of mission & spacecraft design process

Sample: PCW Mission Concept

Orbit: Molniya and Tundra orbits

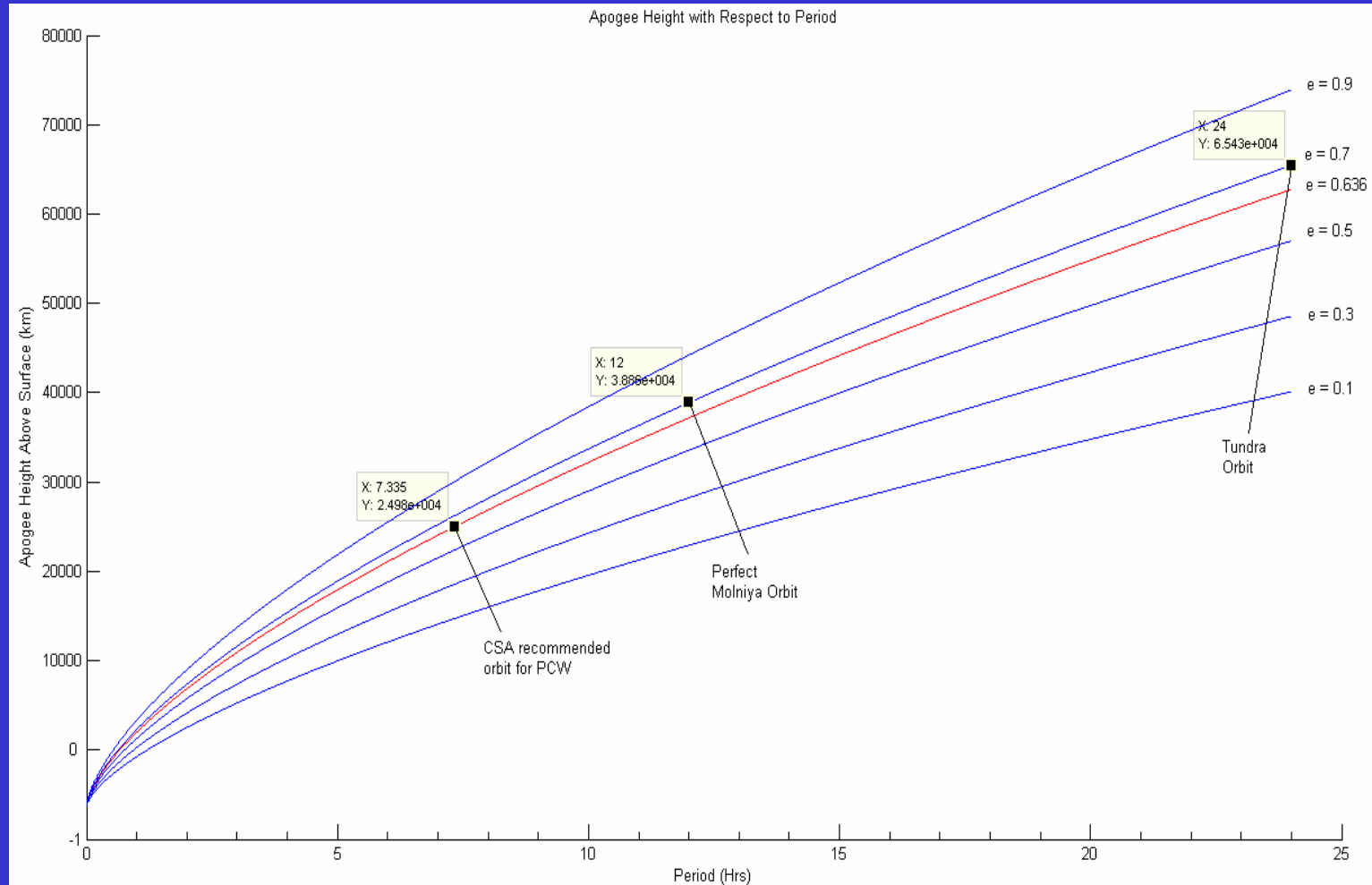

Orbit Selected: Molniya

CSA Recommended

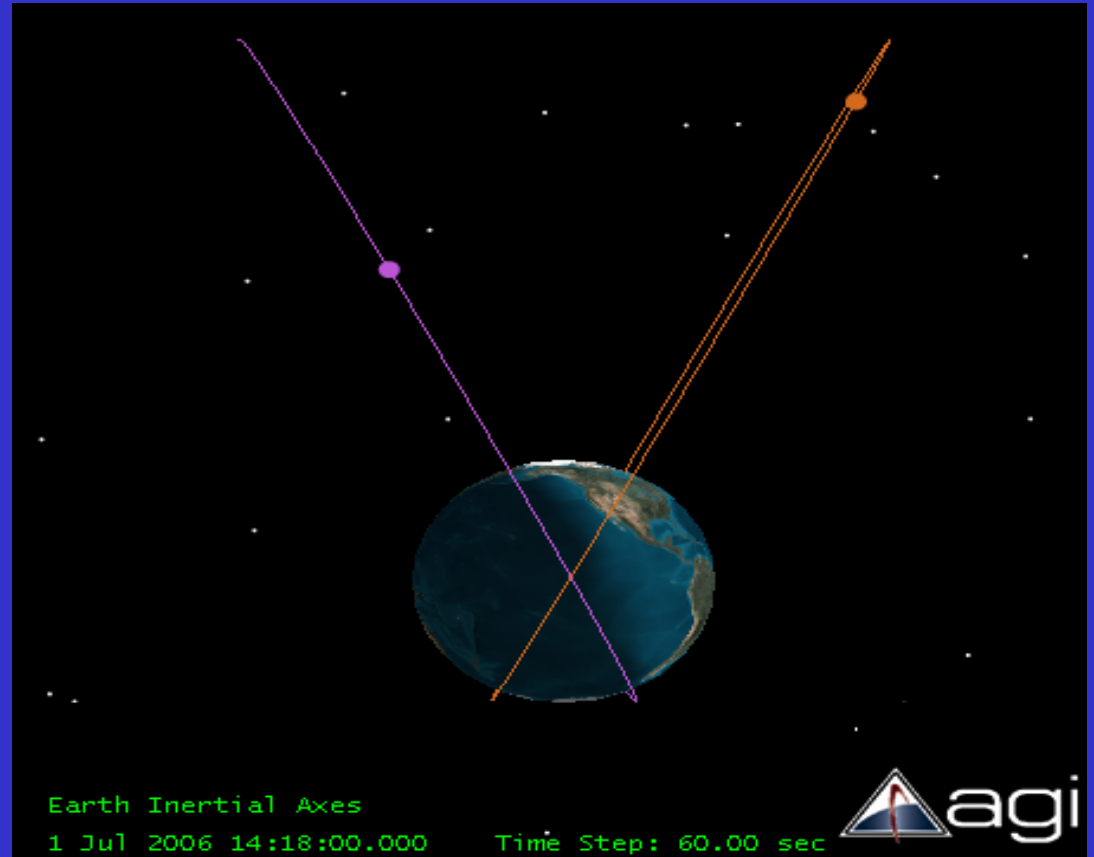
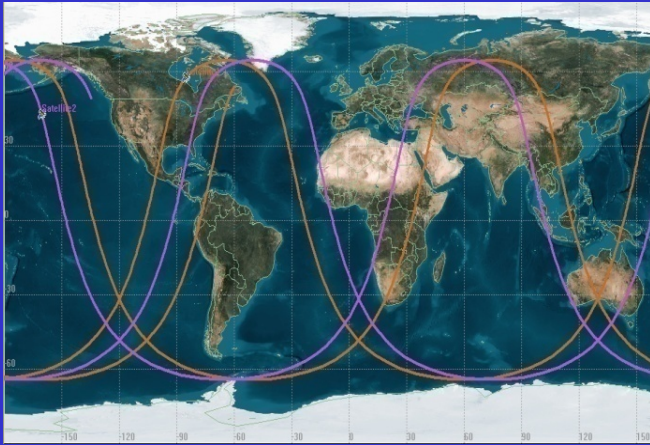

S/C Design Requirement: I: Power Requirements: Power Budget

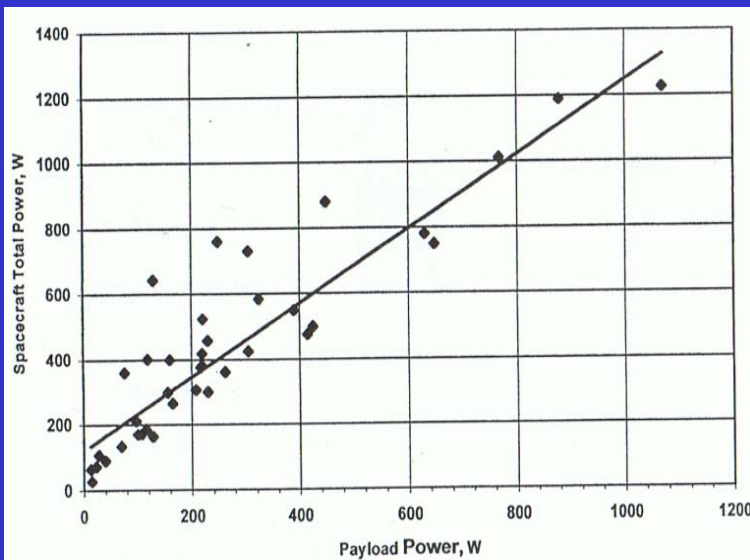

Potential Payload		Average Power (W)
Communications		500
Meteorological	Primary	180
	Auxiliary	45
Total Payload Power		725
Total Power Requirement		941.25
Total Power Requirement with 80% Contingency		1694.25

II: Pointing Requirements

- MODIS flight-model required 10arcsec knowledge and 55arcsec accuracy
- Spacecraft needs to roll 6° from nadir for MODIS coverage
 - Celestial sphere needed for calibration
- Pitch heavily controlled throughout orbit

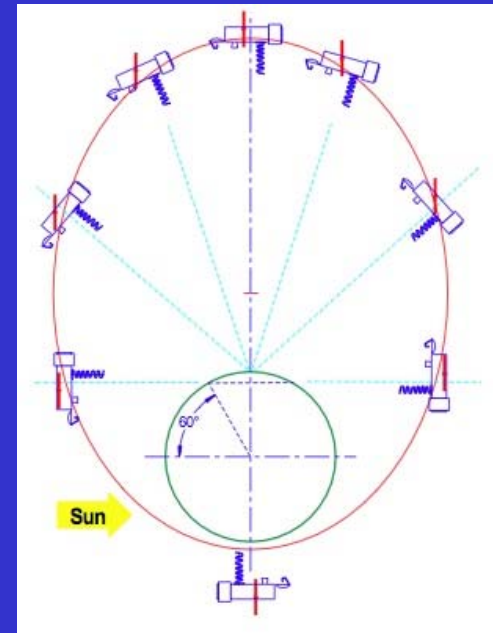

III On-board Data Management

- MIL 1553
 - Serial data bus
 - Data Link layer and Physical Layers
 - Dual redundancy
 - Linear bus
- CAN bus
 - Same as above
 - Signal is encoded using NRZ
 - Linear Bus
- Wireless bus
 - Bluetooth

MIL-STD-1553B Bus

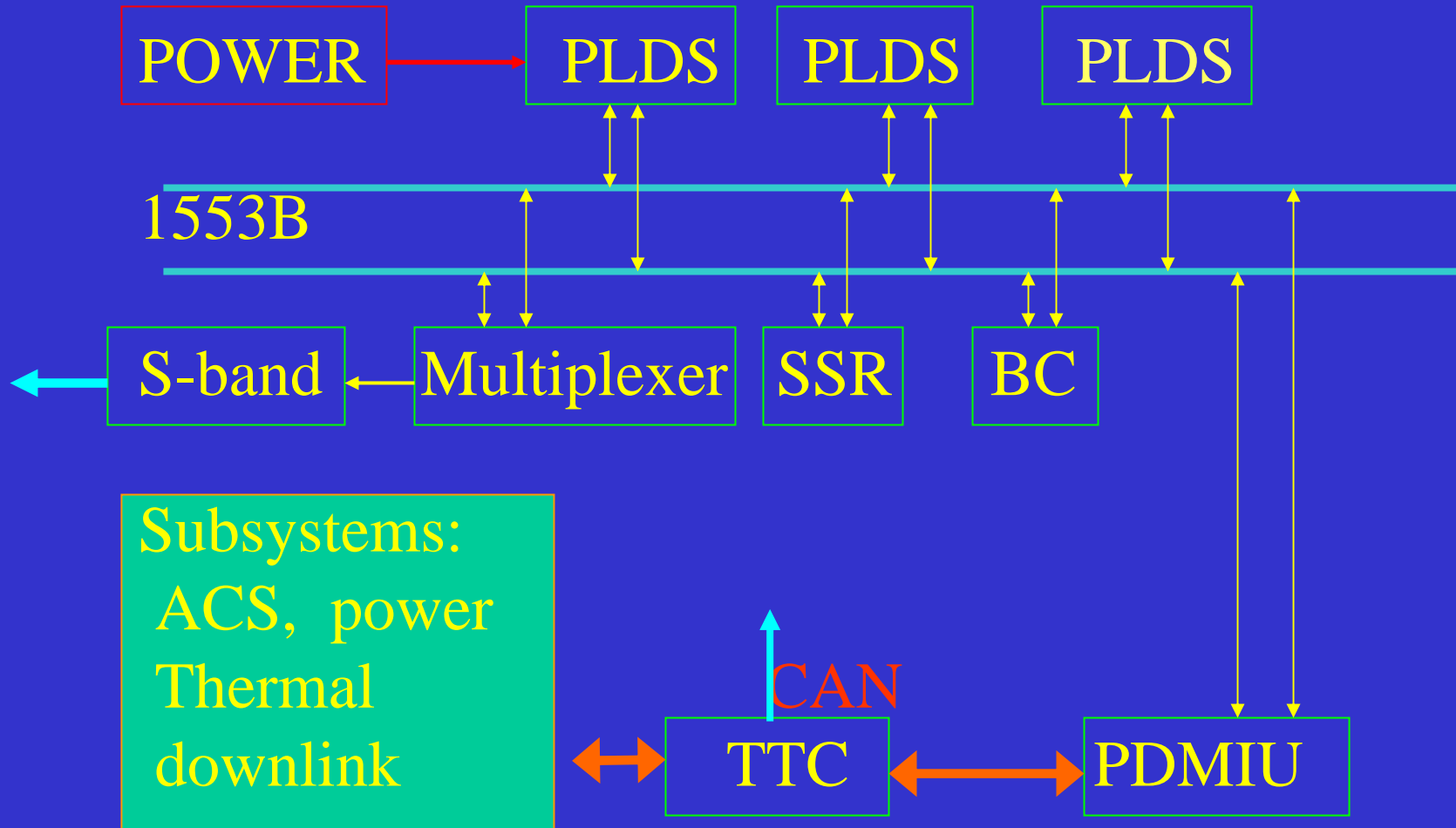

Ionization and Space Hardening

<i>Orbit</i>	<i>Number of orbits/year</i>	<i>Time spent in Van Allan trapped electron belts</i>
40,000 km apogee, 550km perigee	728	2072 hours/year
25,000 km apogee, 550 km perigee	1195	3418 hours/year

- **TID** - Total Dose from all particles
- **SEE** - Single energetic particle effects device
- **Displacement Damage** –
In semiconductors due to scattering interactions of incident particles such protons, neutrons

Fault Toleration - Redundancy

- Error correcting memory
 - parity bits – check for corruption.
 - SEE can effect RAM even when not accessed → use scrubber circuit
- Physical Redundancy
 - Three microprocessor boards
 - Compare their answers, voting logic → real time fail-safe
- Watchdog timer
 - Perform a hard reset of a system unless a certain sequence is performed
 - Write to WDT at regular intervals, failure to do so will mean an incorrect process and the system will restart.

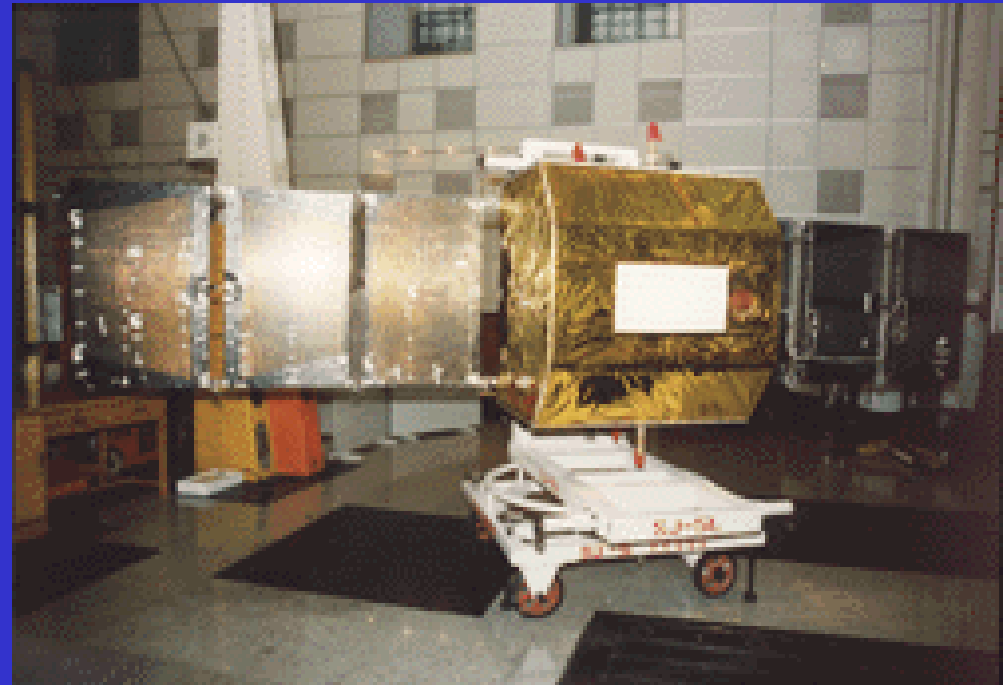

MIL STD 1553B Data Management System (CSSAR, 1999) Standardization of On-Board S-band High Speed Data Management

1.6 Smallsat Development

1.6.1 Minisat Program:



Practice-4, Feb 8, 1994



Practice-5, May 10, 1999



Explorer-1



DFH-1



Alouette

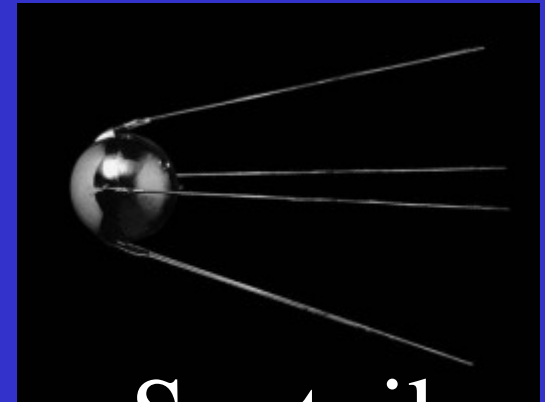

Sputnik

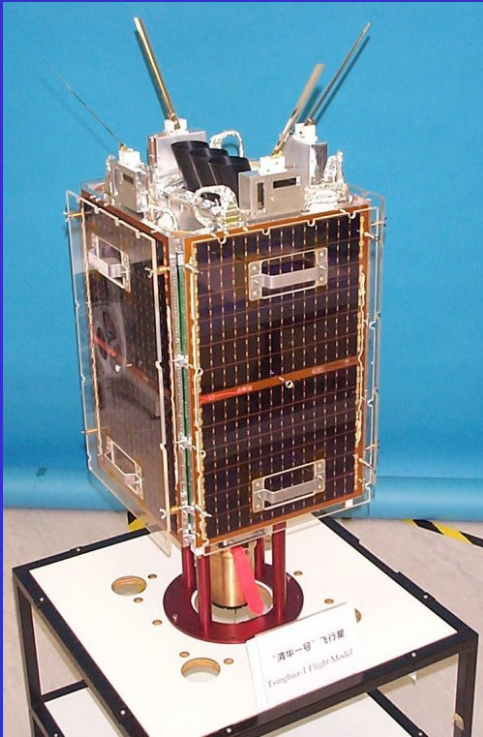

Qinghua-1 (2000)
SSTL, 50Kg

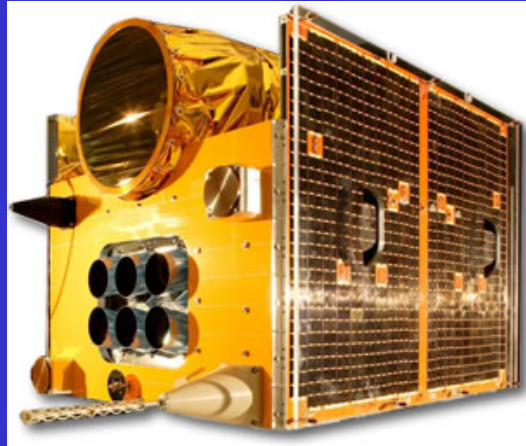

Beijing-1 (2004)
SSTL, 78Kg

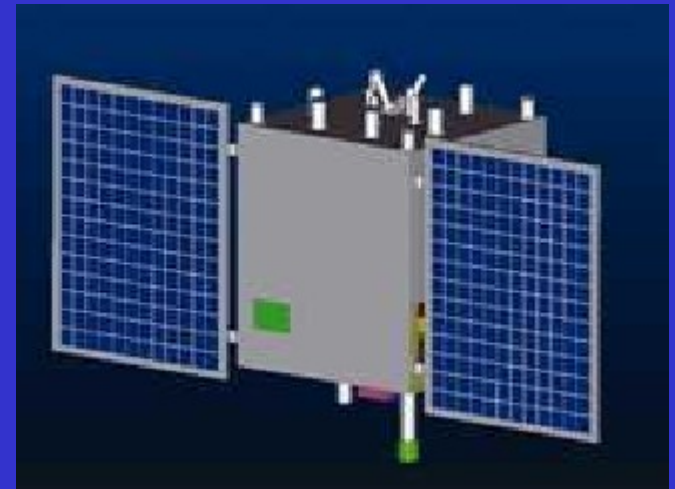

Space Debris Probe, 80Kg

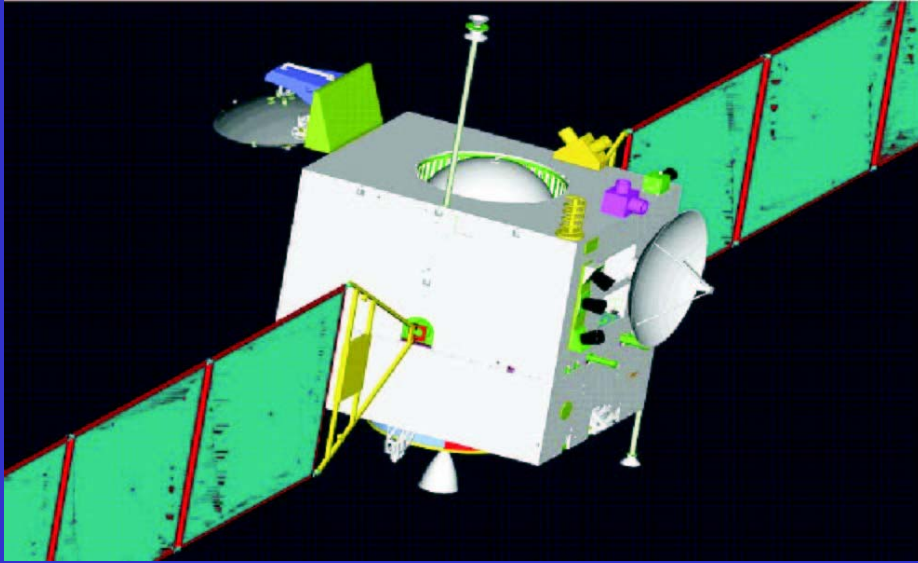

40s Platform for Lunar MicroRover Exploration (Orbitor)



UoSat 12, Lunar exploration

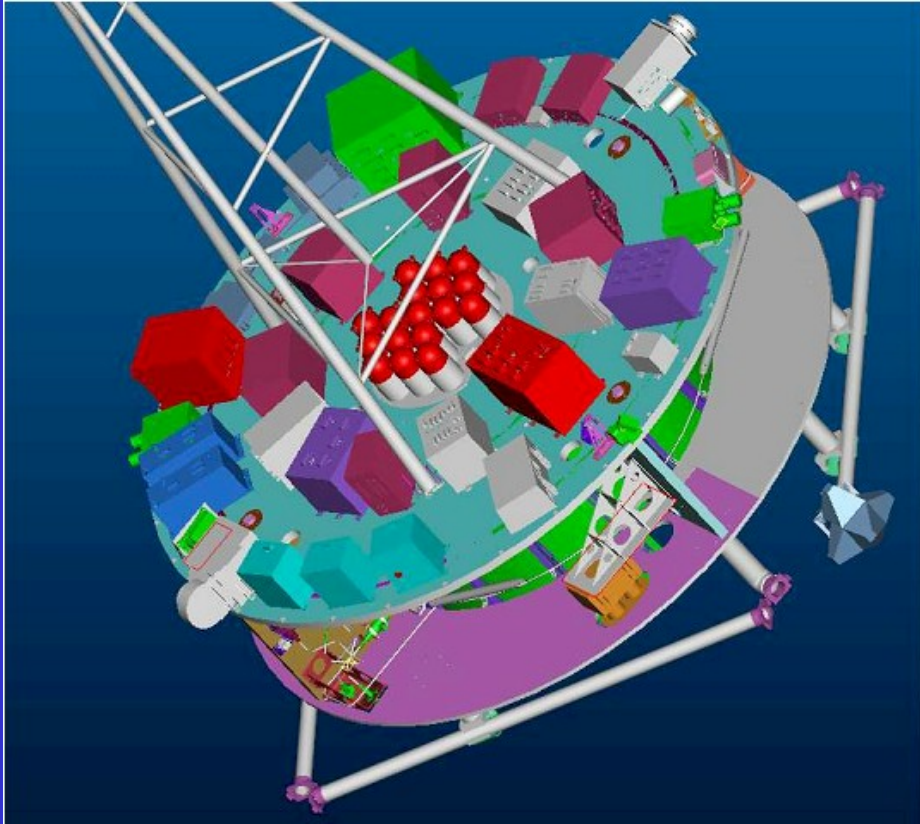

York Education Satellite Program (YESAT)

Why YESAT not Mission?

- Educational needs – always
Mission needs – limited
- Education satellite – low-cost, ample training opportunities
Mission satellite – high-cost, limited training opportunities
- Education satellite – always in York, long-term publicity
- Mission satellite – gone with mission, short-term publicity



YES Program

Starting in 2003 ...

- **NanoSat and Swarms Design**
- **MicroSat and Constellation**
- **MiniSat**

Satellite Bus	YES-1	YES-2
Mass(Kg)	50-120	200-300
Payloads bearing capacity	50%	40% - 60%
Layout	Cube or Central cylinder with rigid substrate panel	
Orbit	sun synchronous orbits, near circular orbit and LEO	sun synchronous orbits at altitude of 500 to 1000Km
Attitude control mode	3 axis stabilization	3 axis stabilization or spin axis stabilization
Attitude knowledge accuracy	0.3 to 0.01 degree (3 sigma)	<0.03 degree (3 sigma)
Pointing accuracy	0.6-0.1degree	<0.1 degree
Attitude stability	0.05-0.005 degree/second	<0.0005 degree/second
Attitude and Orbit control	offset momentum wheel plus magnetic control with orbit maneuver and maintenance capability	mainly offset momentum wheel plus magnetic control, or reaction wheel plus magnetic control with orbital maneuver and maintenance
On-board Data handling	CAN bus technique and Packaging Telemetry system	CAN bus technique Or 1553B bus or others
TTC	USB with GPS orbit determination as supplementary	USB with GPS orbit determination as supplementary
Data Storage	4Gbits	8Gbits
Data Downlink	S band, 2Mbps	S band or X band, 4Mbps
Solar array output	200W	800W
In-Space Propulsion	Chemical Thrusters	Hydrazine(N ₂ H ₄) or cold gas propulsion system with orbit maneuver and maintenance Capability *Electrical Engine is next step



York Education Satellite Program (YESAT)

Why YESAT not Mission?

- Educational needs – always
Mission needs – limited
- Education satellite – low-cost, ample training opportunities
Mission satellite – high-cost, limited training opportunities
- Education satellite – always in York, long-term publicity
- Mission satellite – gone with mission, short-term publicity



York Education Satellite Program

YESAT

Approaches:

- Students design & create microsatellite & scientific payloads
- Practical Hands-on with state-of-the-art technology
- Get students involved with CSA and Canadian space industry
- QuickSat Tech for Education and training?!

York Education Satellite Program

YESAT Road Map

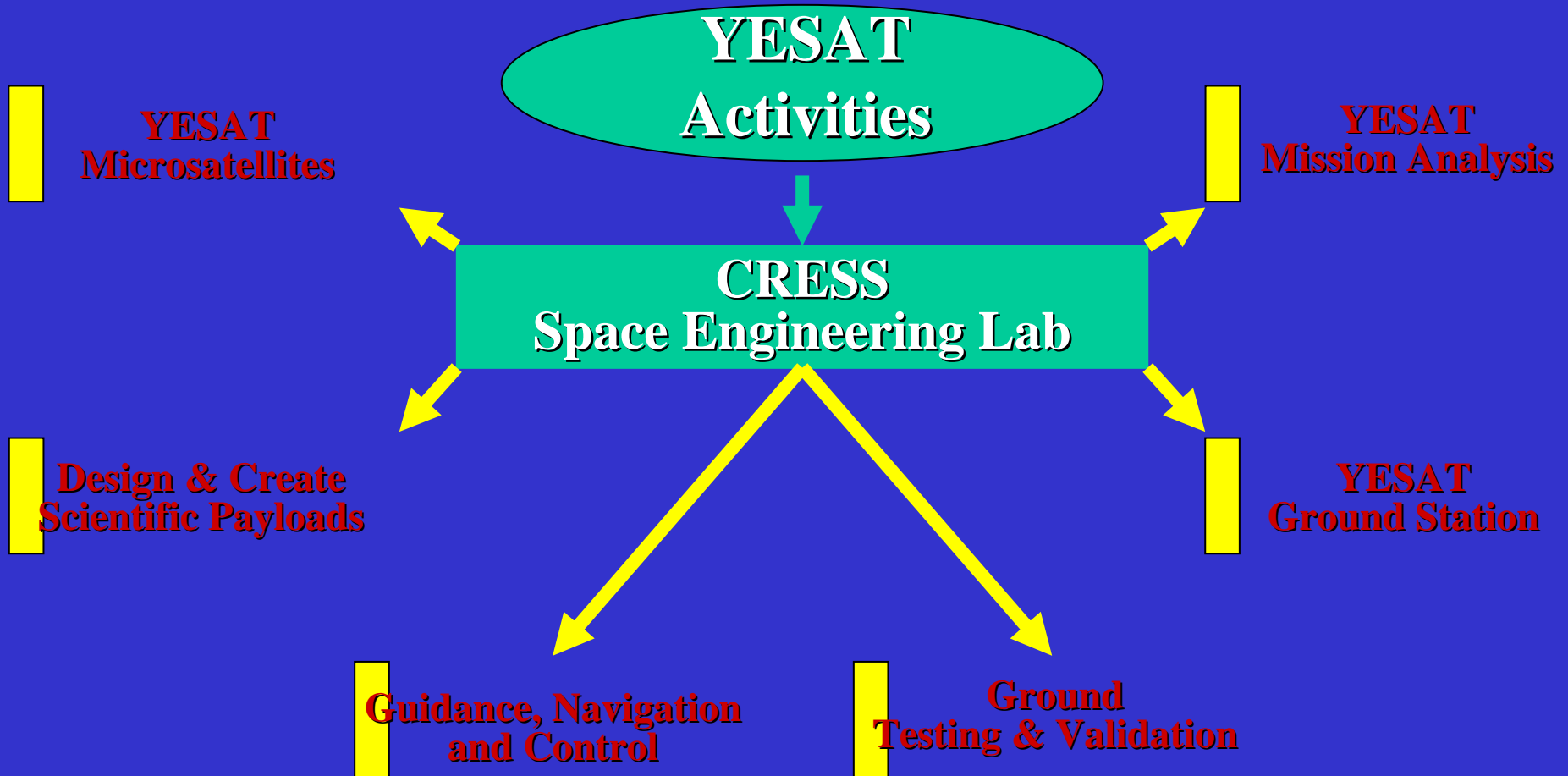

QuickSat (CSA) at York for Education

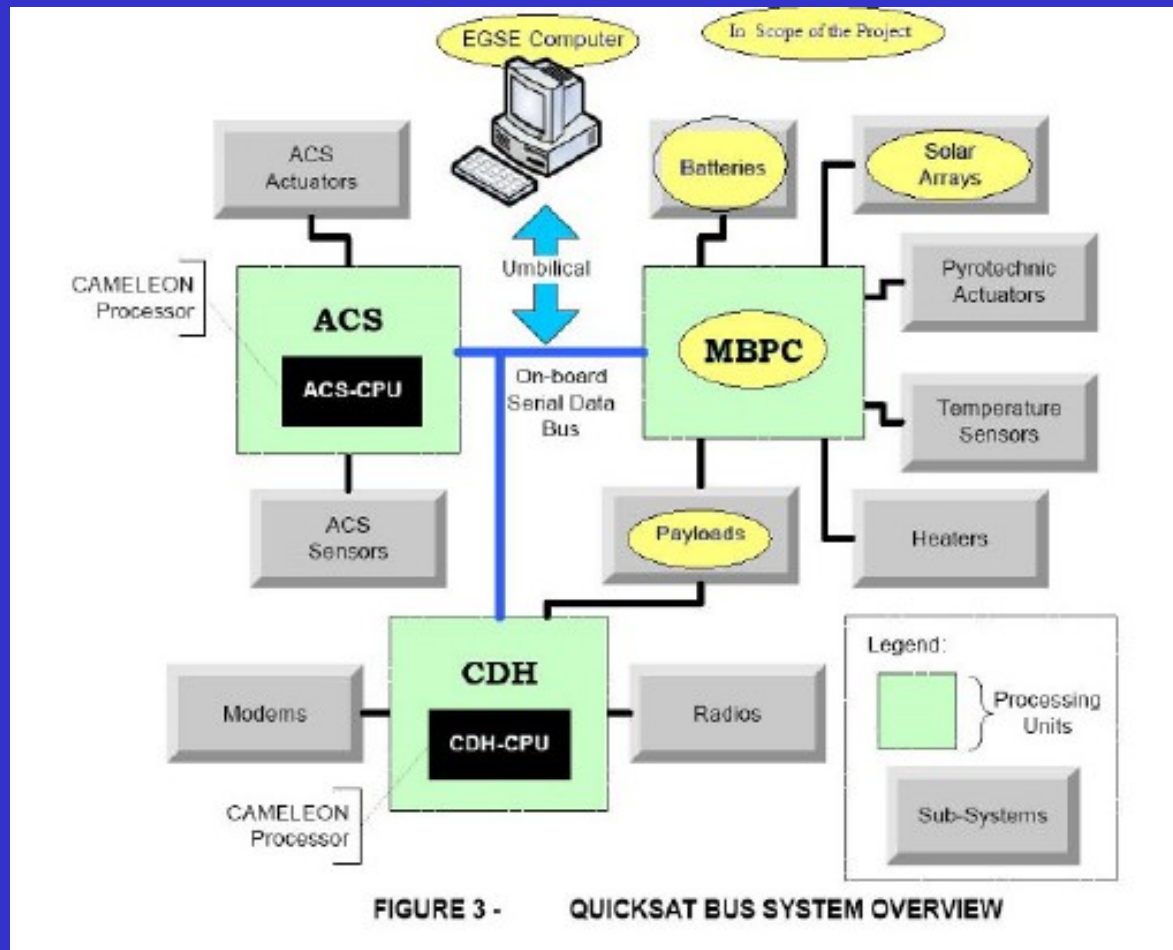

QuickSat (CSA) at York for Education

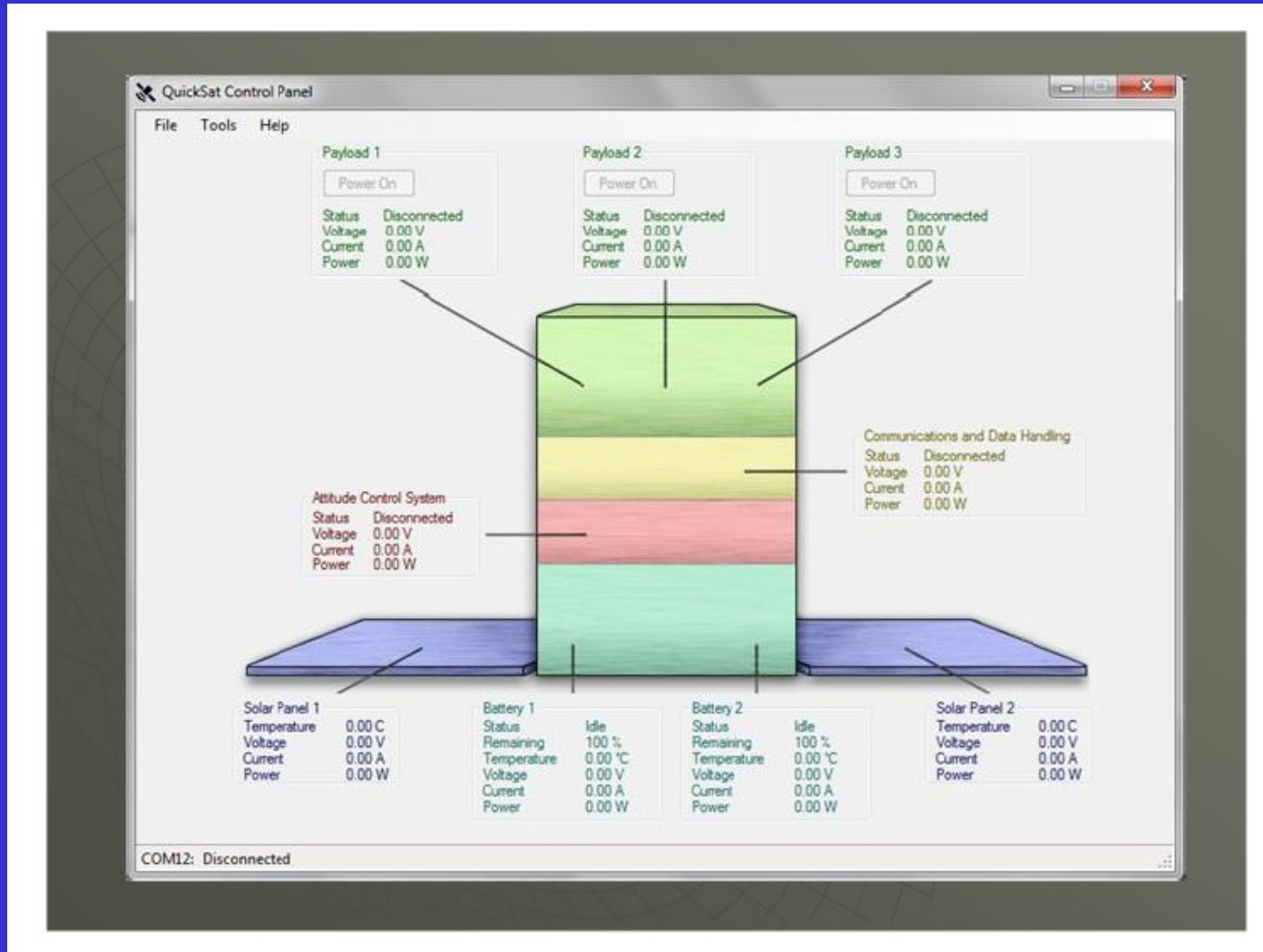

2. Research in the Space Environment and its Effects

2.1 Characterizing Space Environment and its Effects

Space System:

Atmospheric Drag

Microgravity

Vacuum

Temperature

Solar UV

Atomic Oxygen

Radiation

Charging and Discharging

Total Ionize Dose

Single Event Effect

Outgas and Contamination

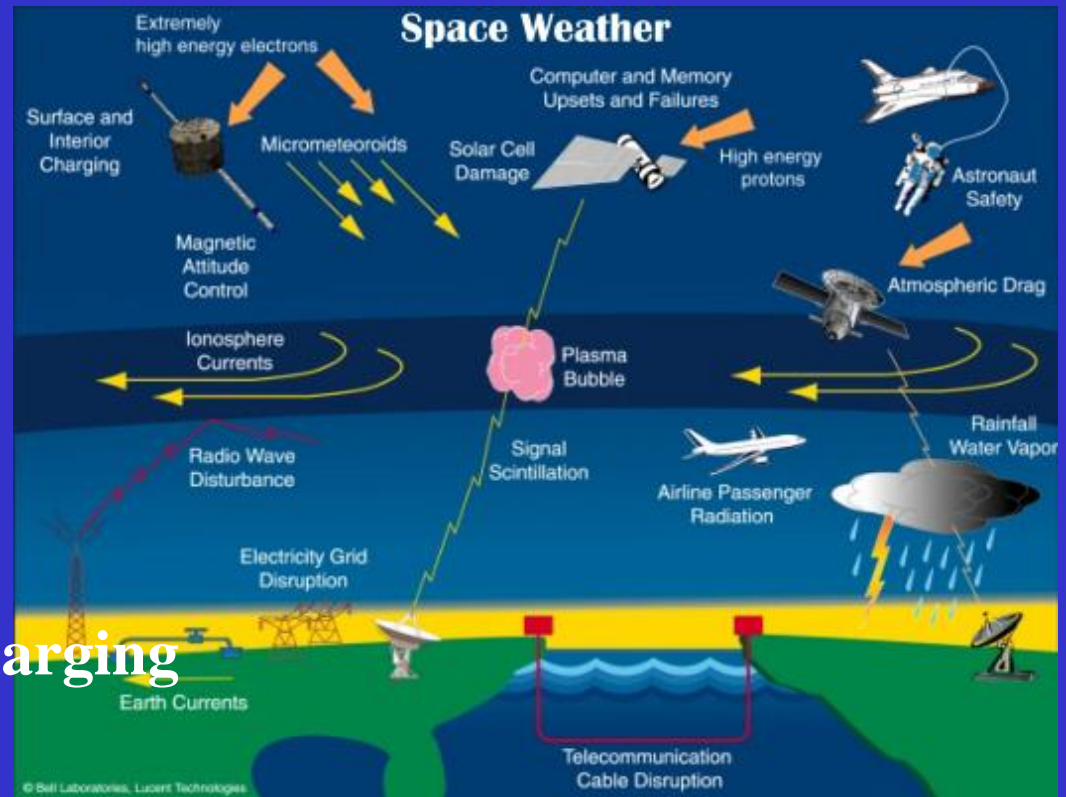

Space Radiation

- Cosmic Ray
- Solar Flare
- Coronal Mass Ejection



Trapped Charge Particles and Radiation Belt

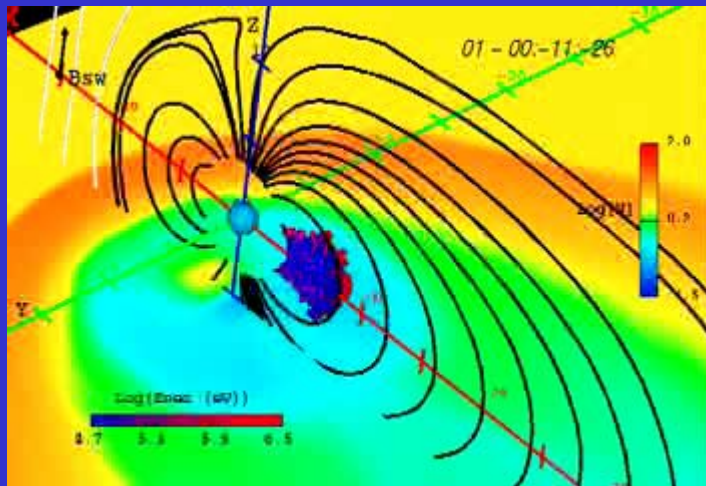

e

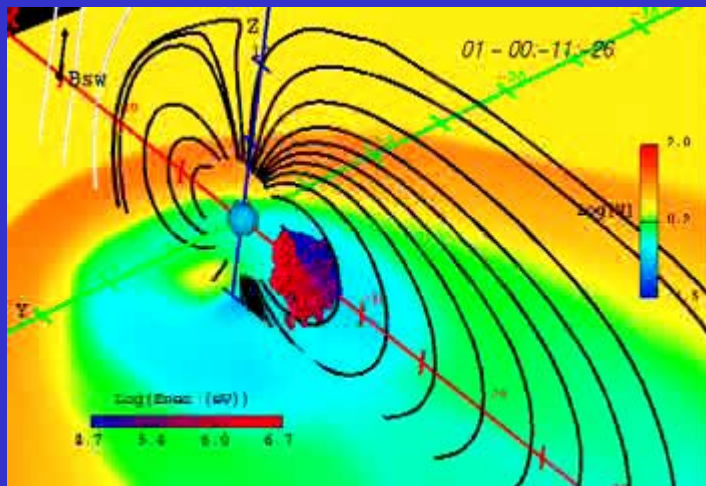
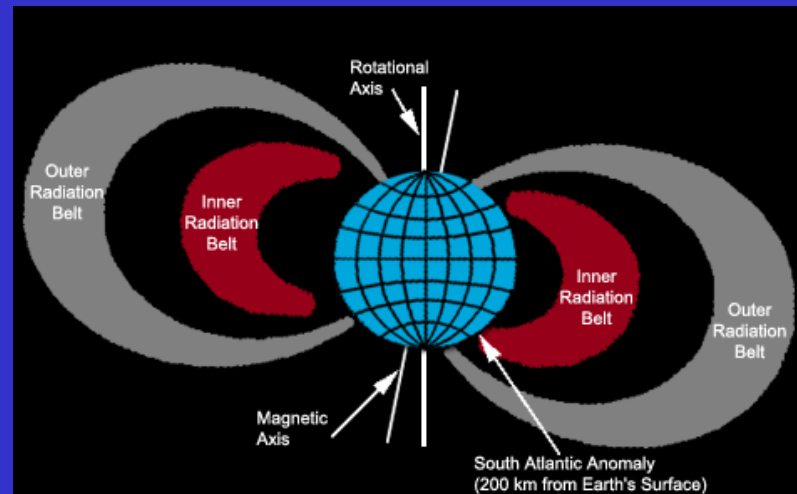

p

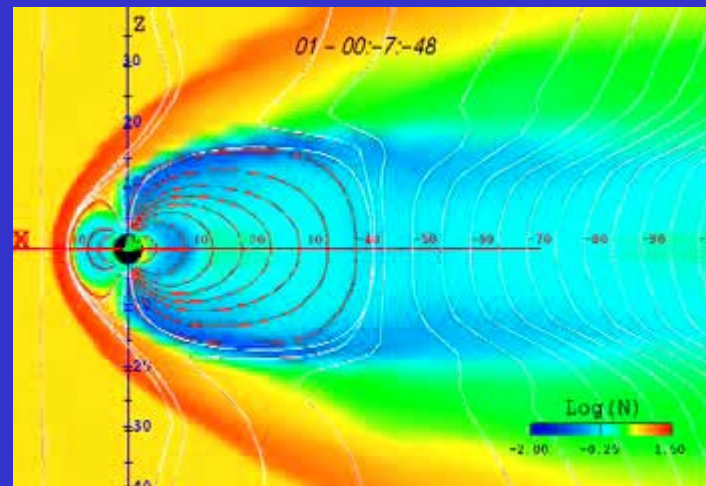

SEE in Avionics

Atmospheric neutrons

- Launch system
- Aircraft



2.2 Monitoring, Simulation, Testing, Protection and Mitigation

Monitoring

- Science Mission
- Space Environment Monitoring (SEM)
System on board application satellite:
Remote Sensing Satellite
Weather Satellite

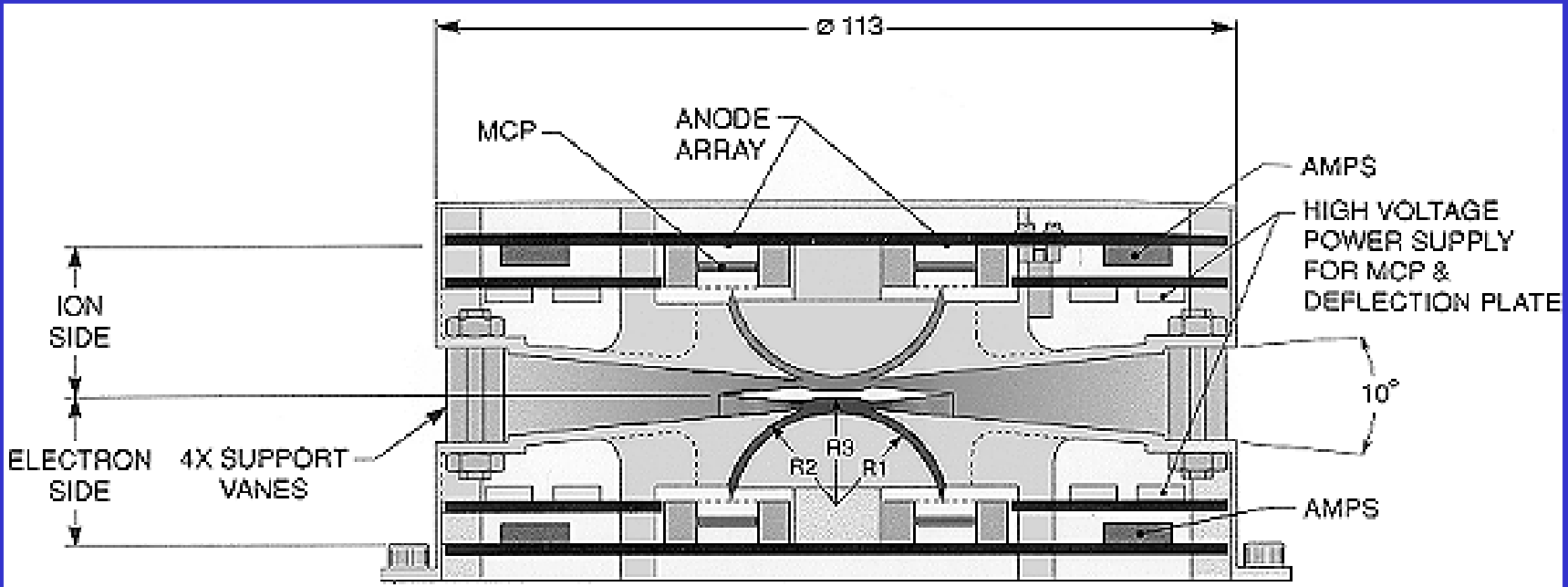

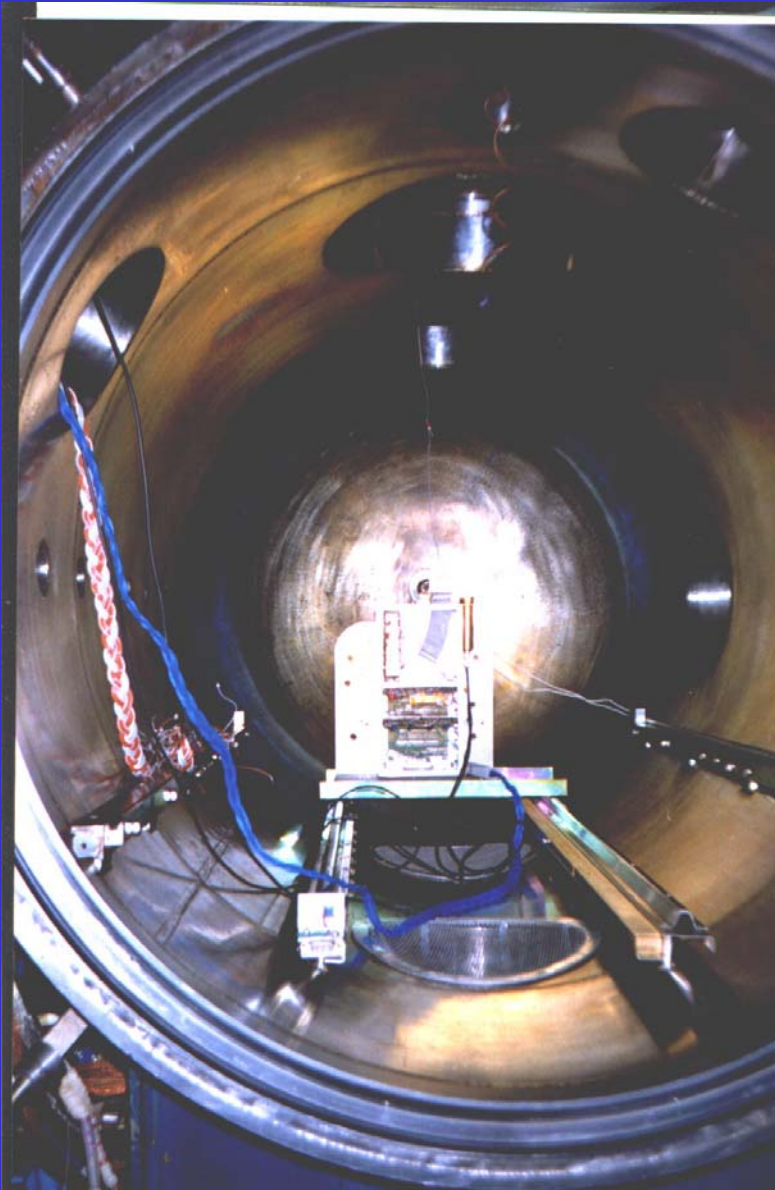

Calibrate
Low energy Particle
Detector
For SZ Space
Environment Monitor

Ground Testing

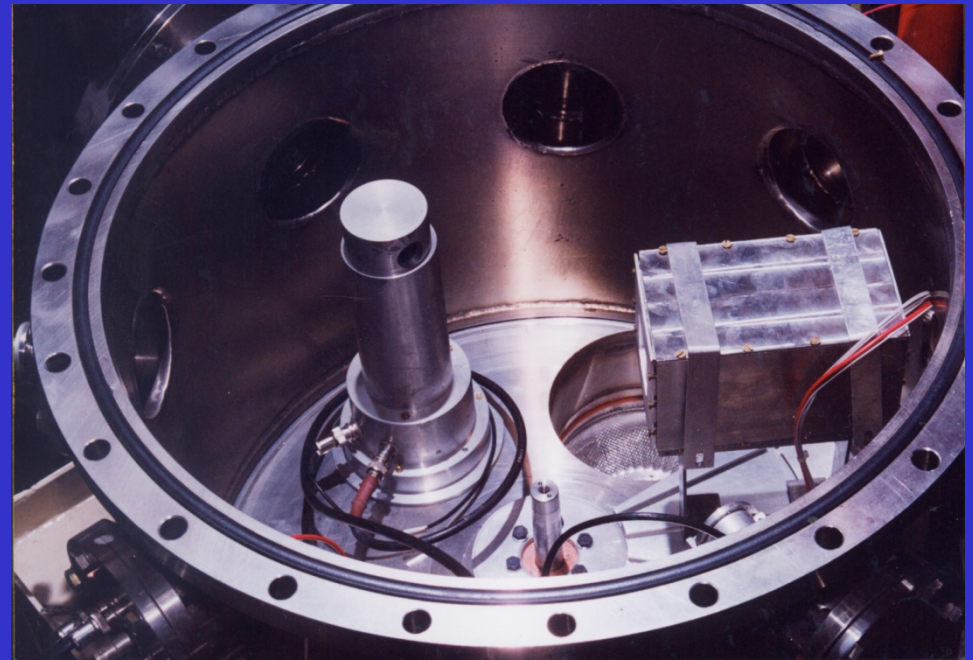
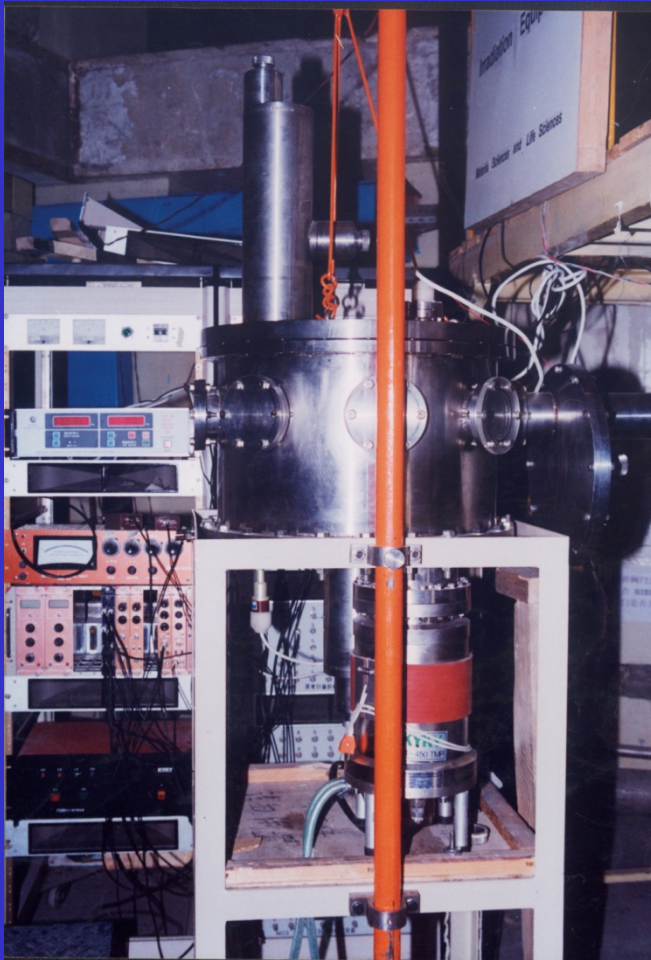

SEU

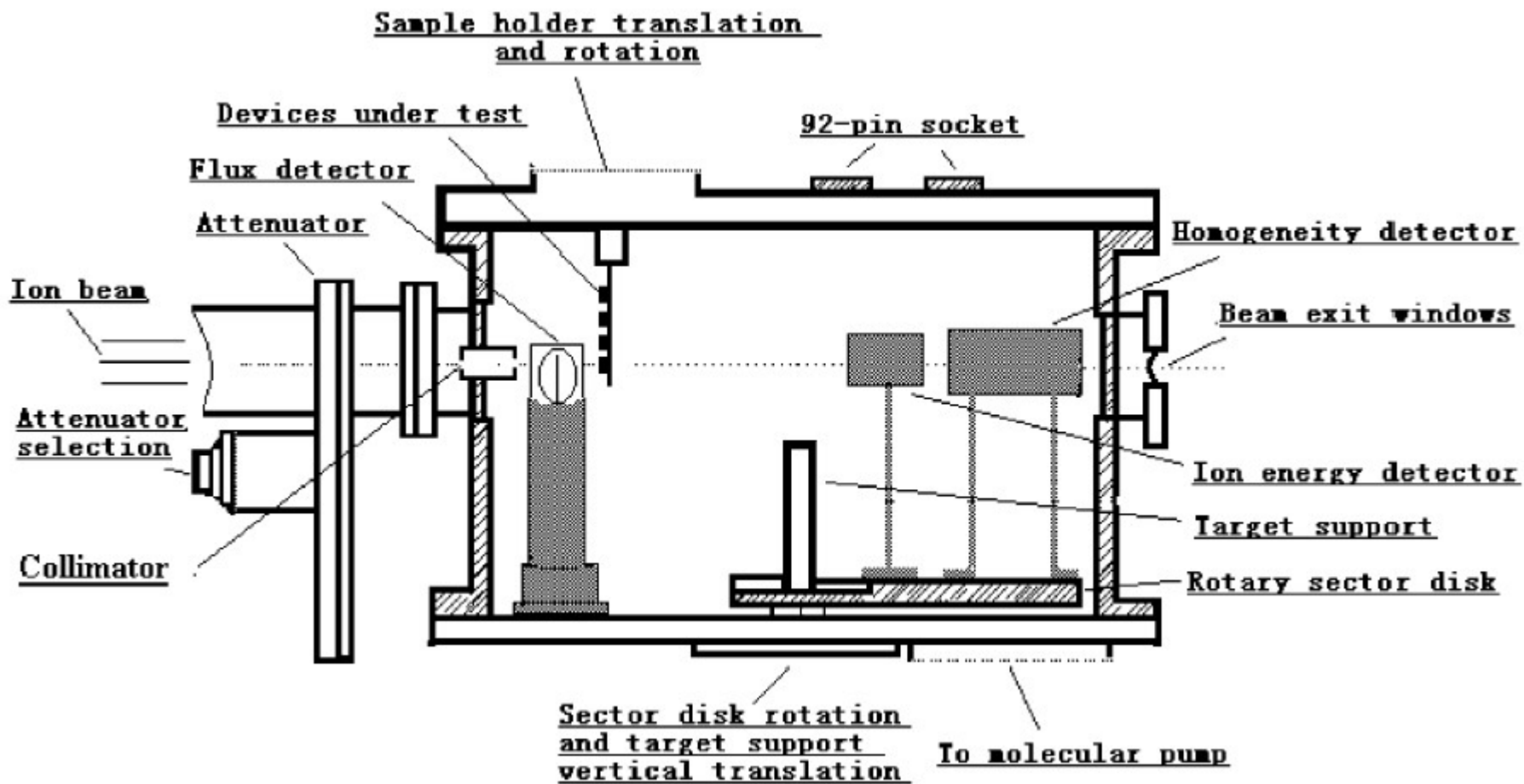

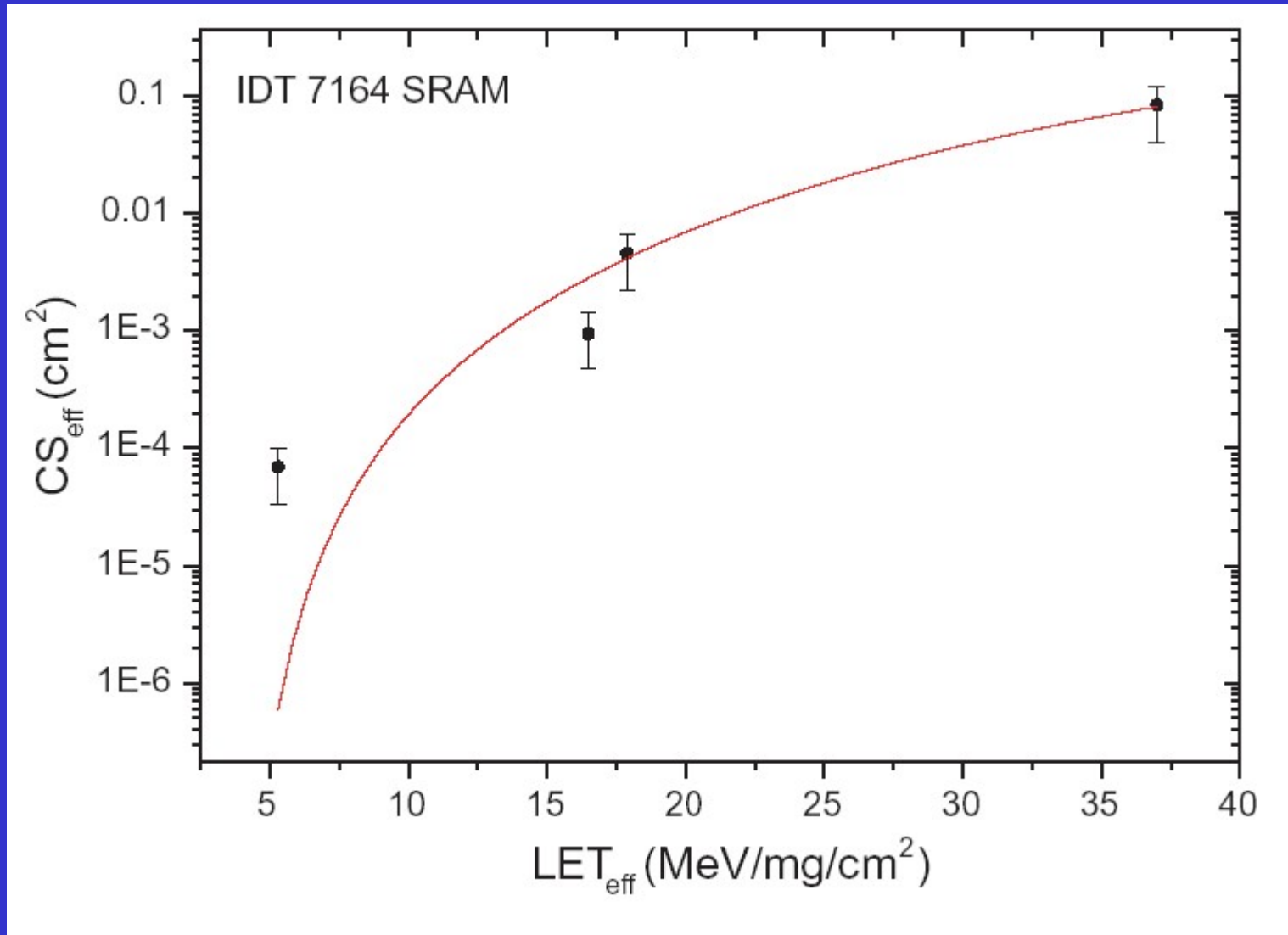

SEE Protect Methods

- **Shielding Material®**
- **Two CPU redundancy**
- **Reed-Solomon coding Correction**
- **Software Self-correction**
- **Smart controller against SEL**



252Cf for SEE test

More than 1000 ICs have been tested.
Among them: PC104, Electronics Stack
used in NASALaser communication
guidance system

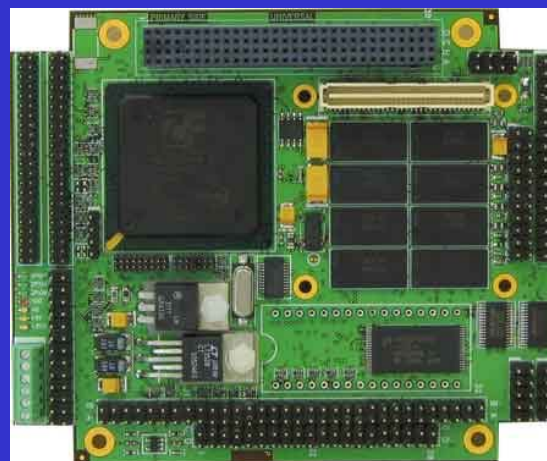

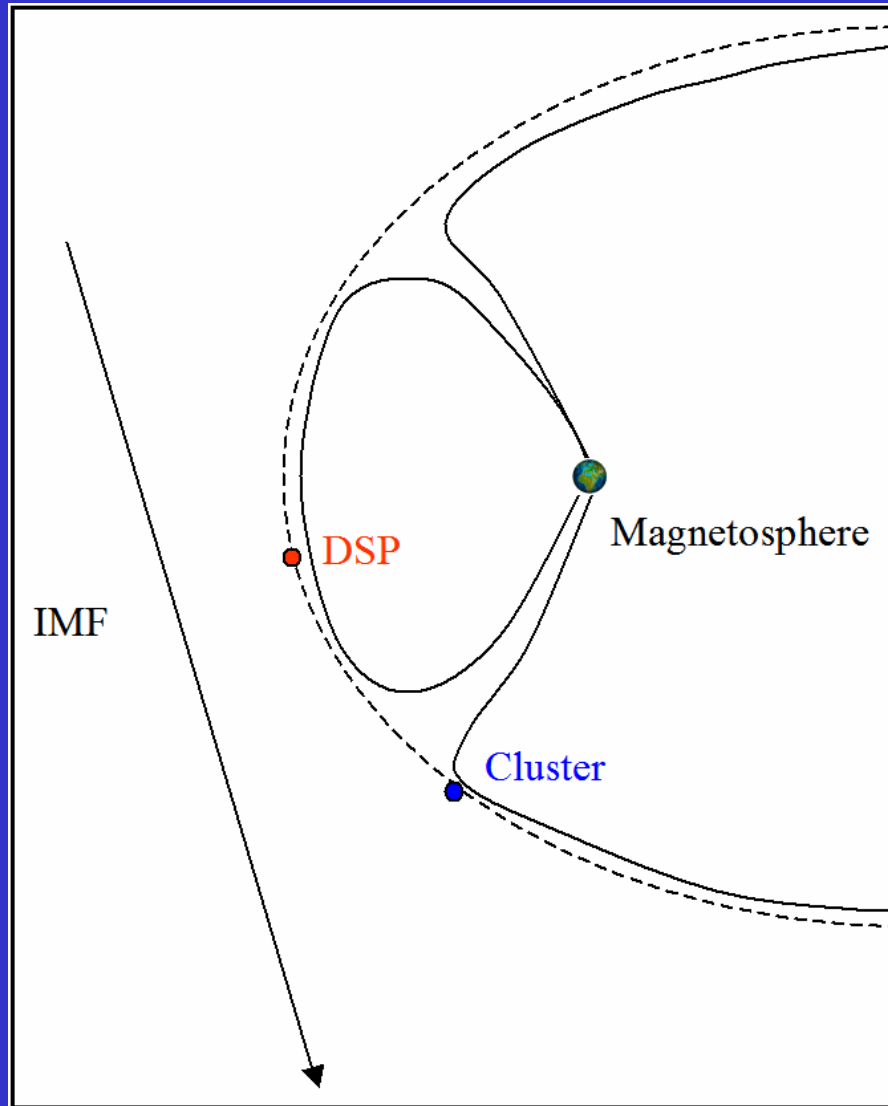

TC1 data for 2004.03.26

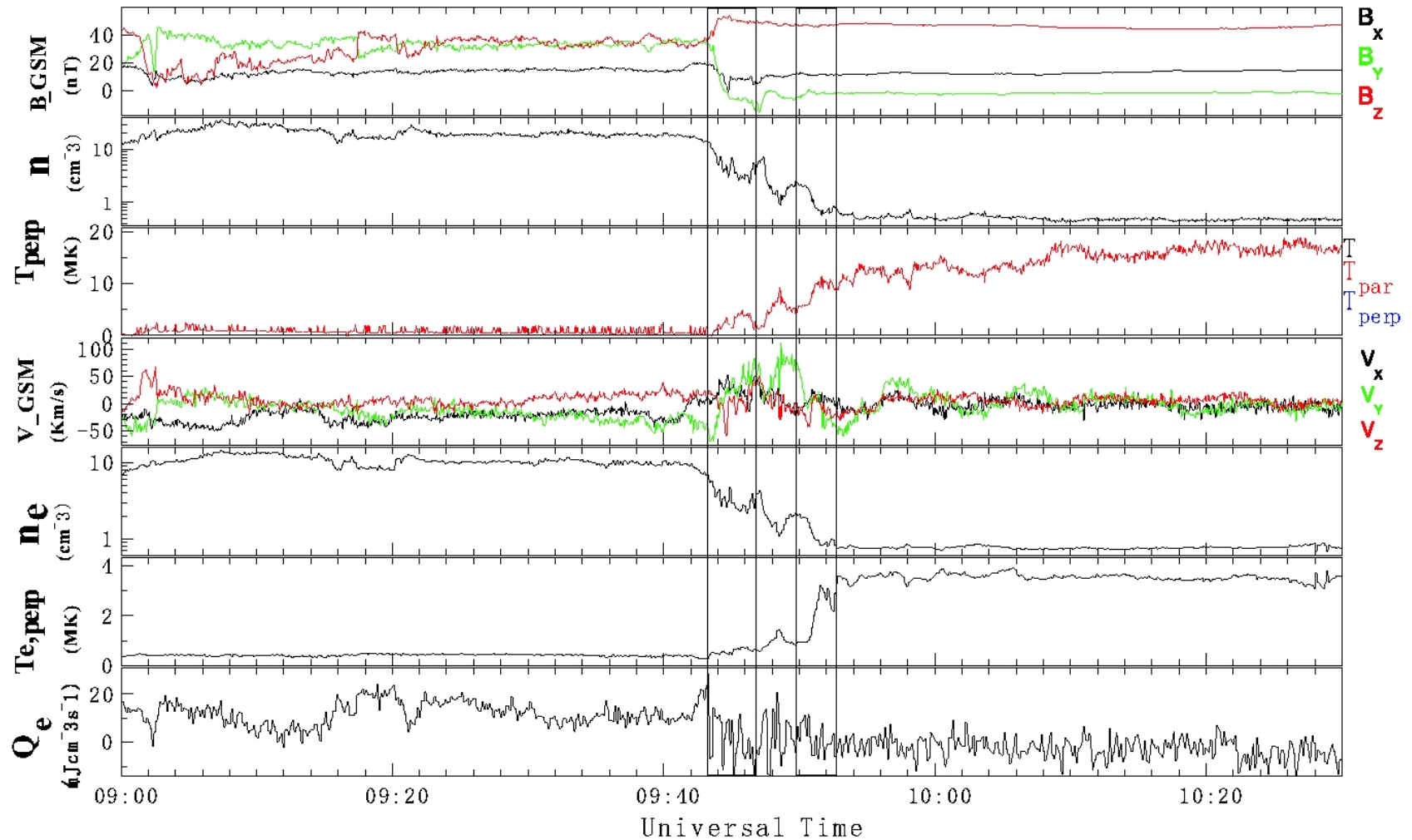

Aurora and night glow - 6300A aurora an ISIS-II spacecraft Experiment

The 6300A emission arises from de-excitation $O(^1D) \rightarrow O(^3P) + h\nu(6300A)$

Excitation by secondary electrons

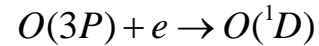

Thermal excitation by heated electrons

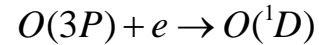

Dissociated recombination of O_2^+ ions

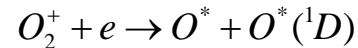

Cascading from $O(^1S)$



The 5577A emission arises from atomic Oxygen $O(^1D) \rightarrow O(^1S) + h\nu(5577A)$

The 5200A emission arises from atomic Nitrogen $N(^2D) \rightarrow N(^4S) + h\nu(5200A)$

Canada's space observation on aurora and airglow

ISIS

Freja (Uv, red line photometer, rocket observations)

Windii

E-POP

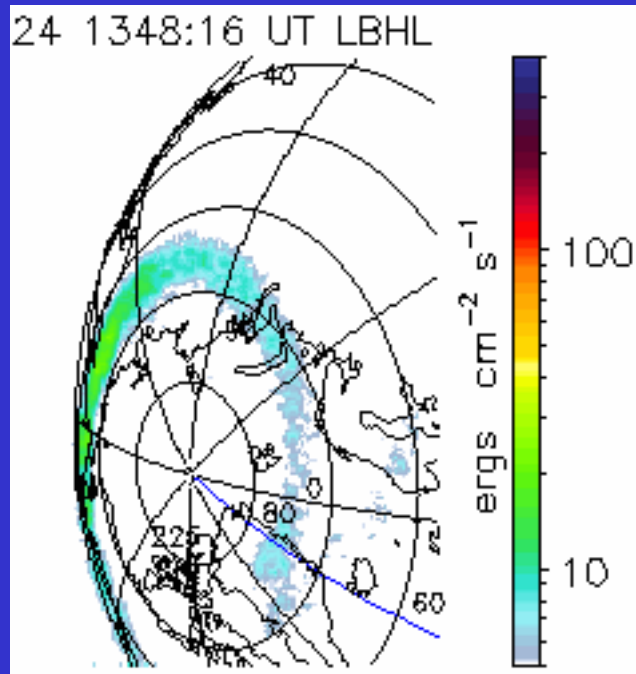

Sub-storm over north China (Killing electrons)

THEMIS:

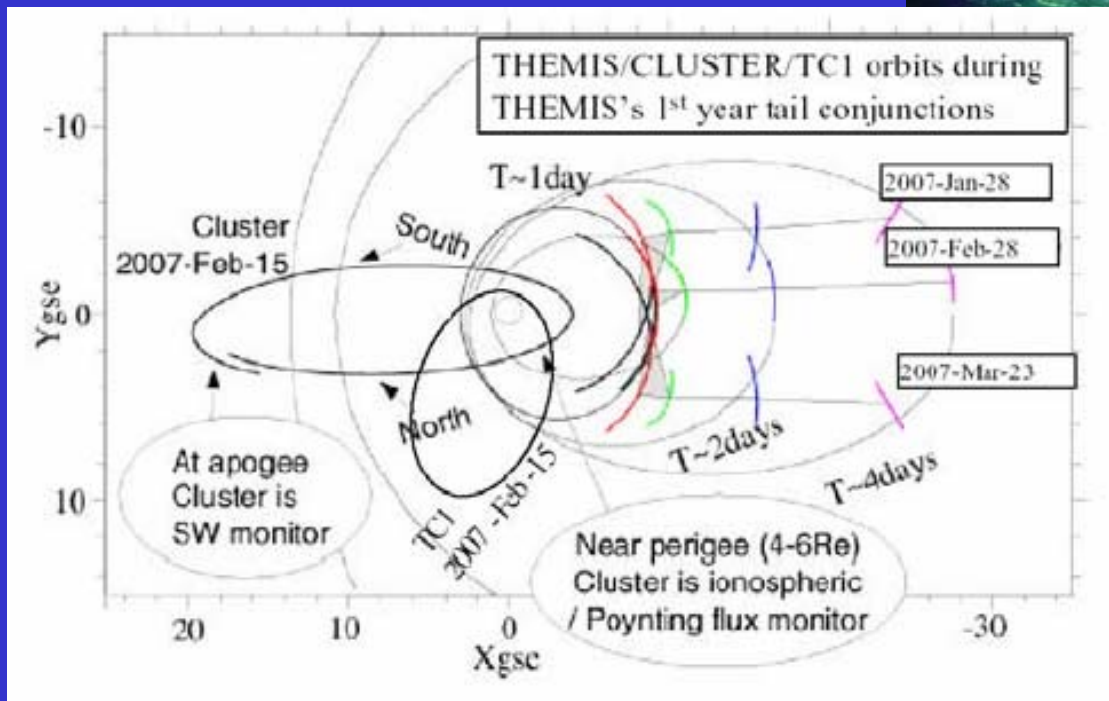
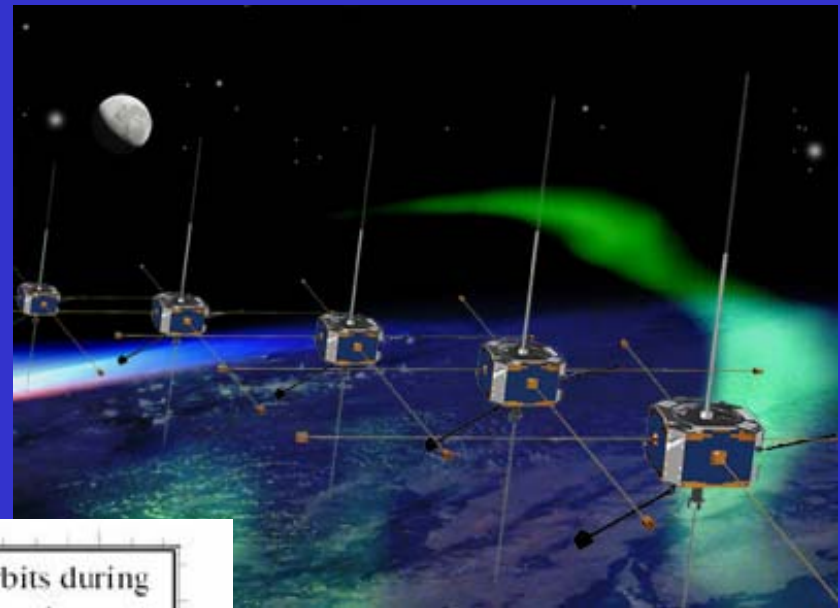

Space Debris:

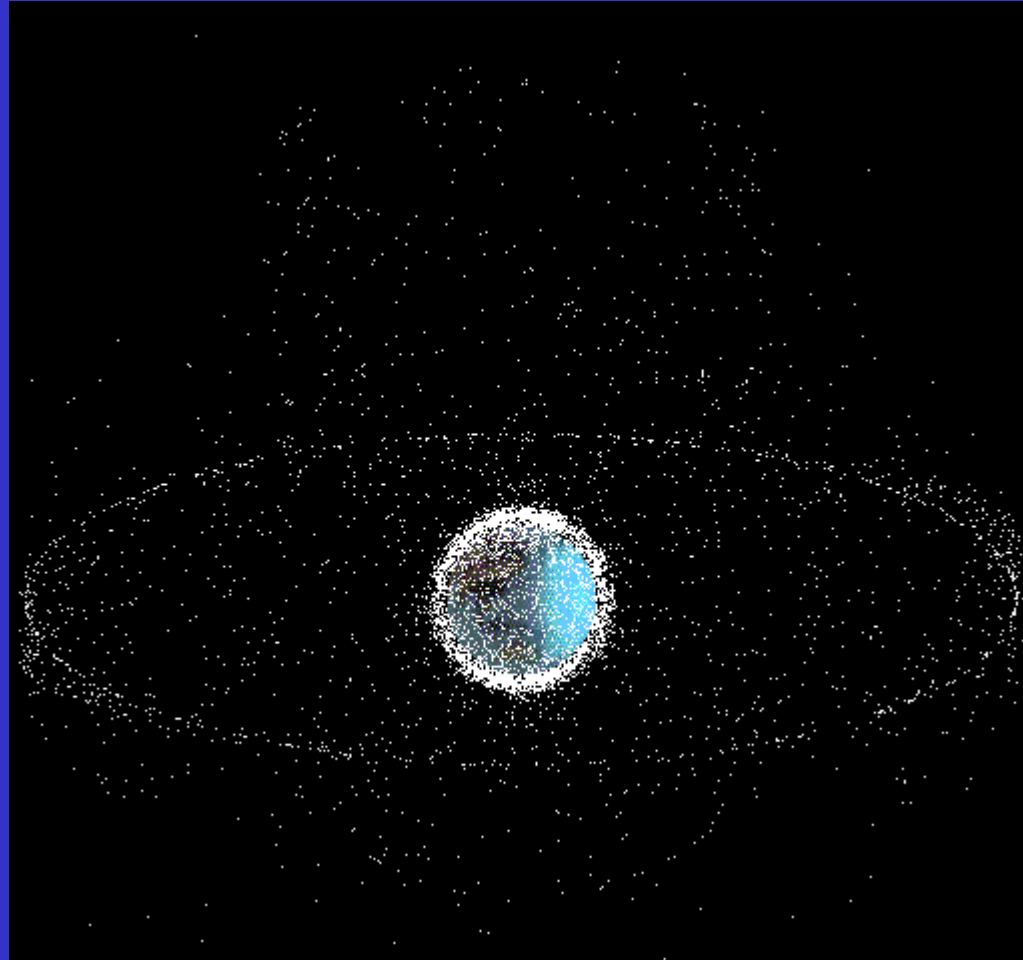

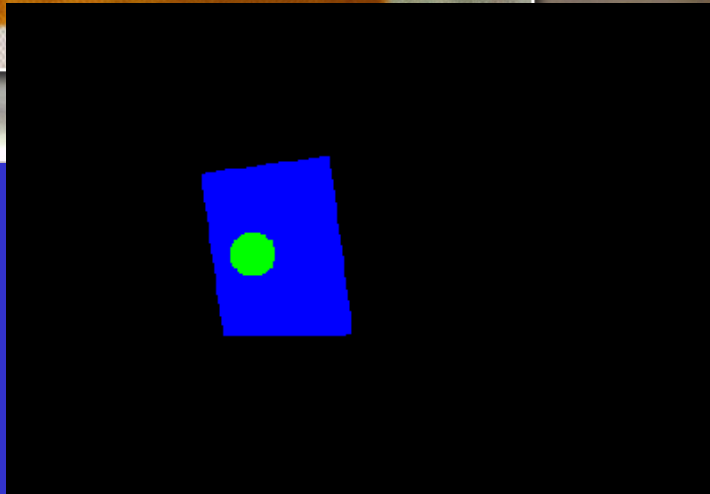

Schematic of radiator and sketch of damage

Micrometeoroid Orbital Debris (MMOD) impact on Atlantis' (STS-115) right hand payload bay door radiator

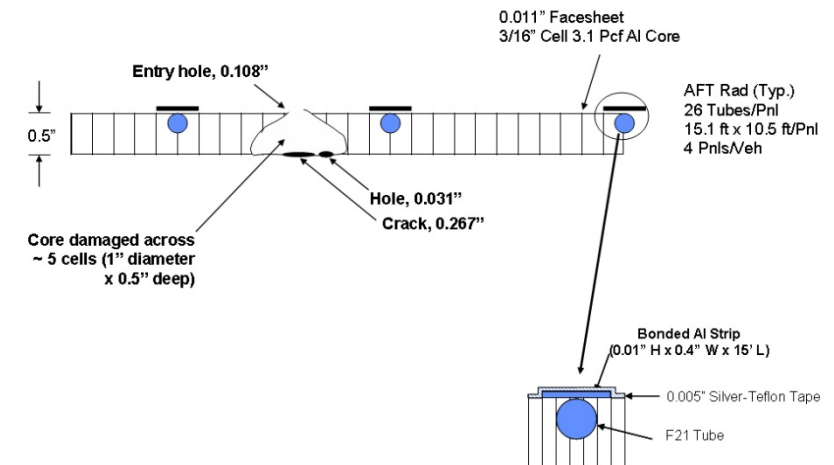

CFHT

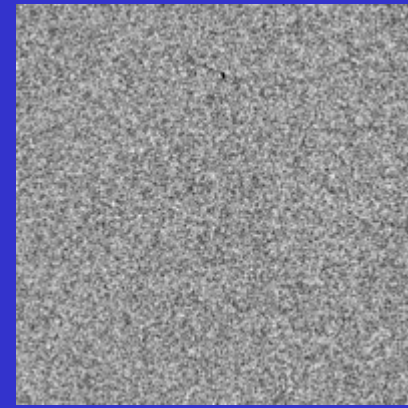

Smart-1's impact dust

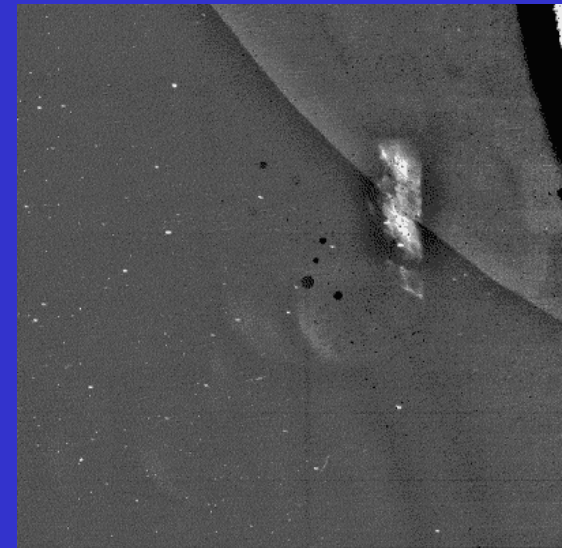

Space Golf (Element 21 Golf Company in Toronto):

3g with tiny GPS receiver

Battery: 5 days

Scaling up for the future

Free-flying test

Atmospheric clean-up



3 Space Optical Instrumentation

3.1 Instrument Development for Spatial Heterodyne Observations of Water

The Spatial Heterodyne Observation of Water (SHOW) project, a new instrument was developed to measure water vapour from 15km to 85km height, through **observing water absorption of the solar scattering light from the atmosphere, in limb configuration**, on a global scale, using the unique capabilities provided by Spatial Heterodyne Spectroscopy (SHS).

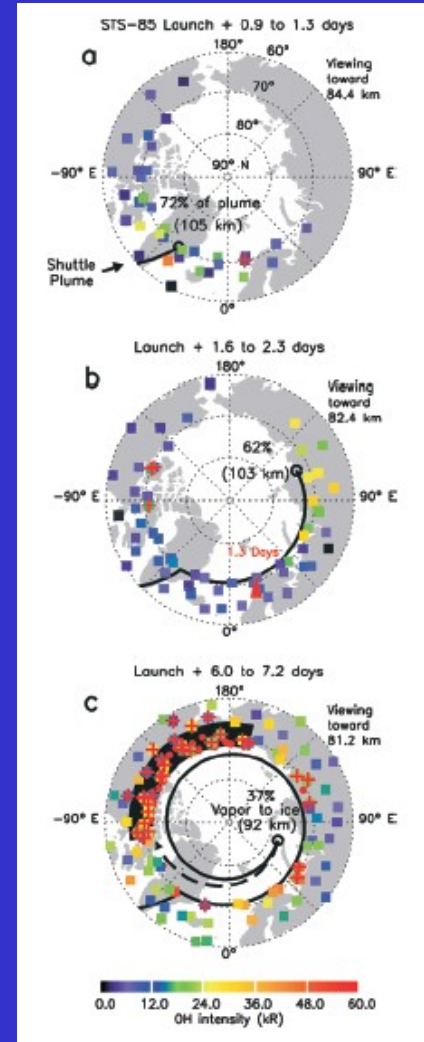

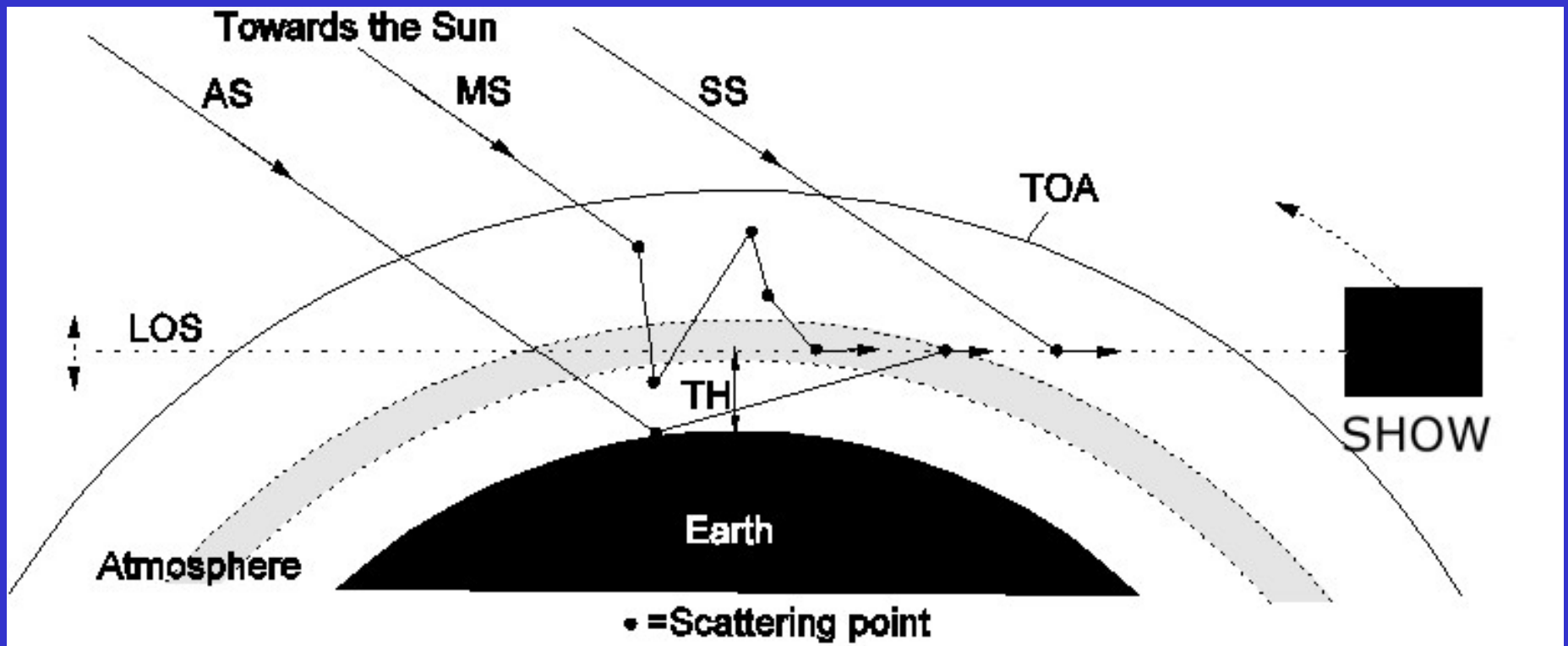

SHOW Viewing Geometry

Limbtran SHOW Simulation

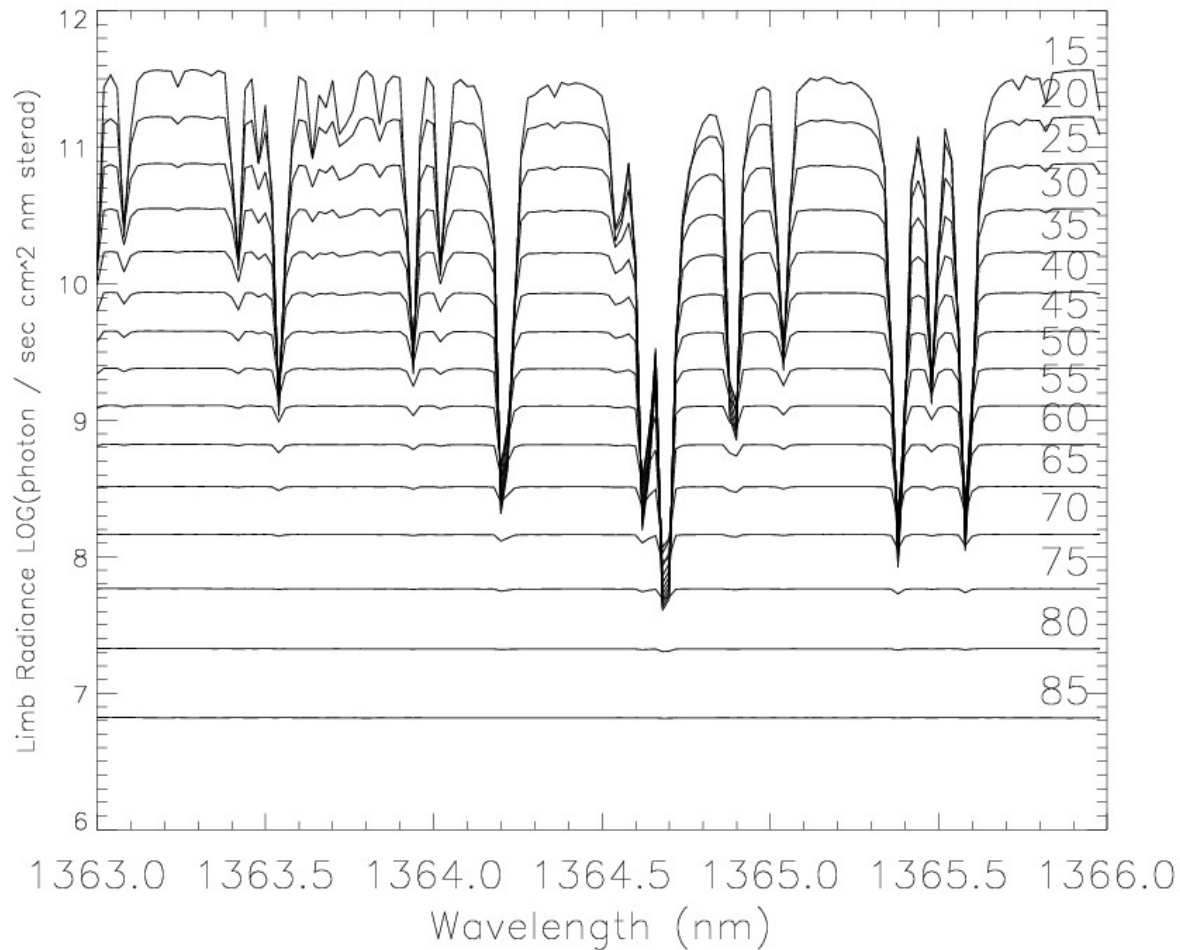

Prediction of SHOW water vapor observation
through the revised LIMBTRAN model

In the general case of a polychromatic source, the intensity $I(x)$ in the fringe localization plane can be written as a function of the spatial dimension x in the dispersion plane:

$$I(x) = \int_0^{\infty} B(\sigma) \{1 + \cos[2\pi(4(\sigma - \sigma_L) \tan(\theta_L) x_0)]\} d\sigma$$

An interference filter is used to reject out of band wavelengths that would result in aliased fringes and/or a non-unique recovery of the incident spectrum.

Field-widened spatial heterodyne spectrometers can be achieved using fixed field-widening prisms. Field-widening enhanced the light collecting power for SHS.

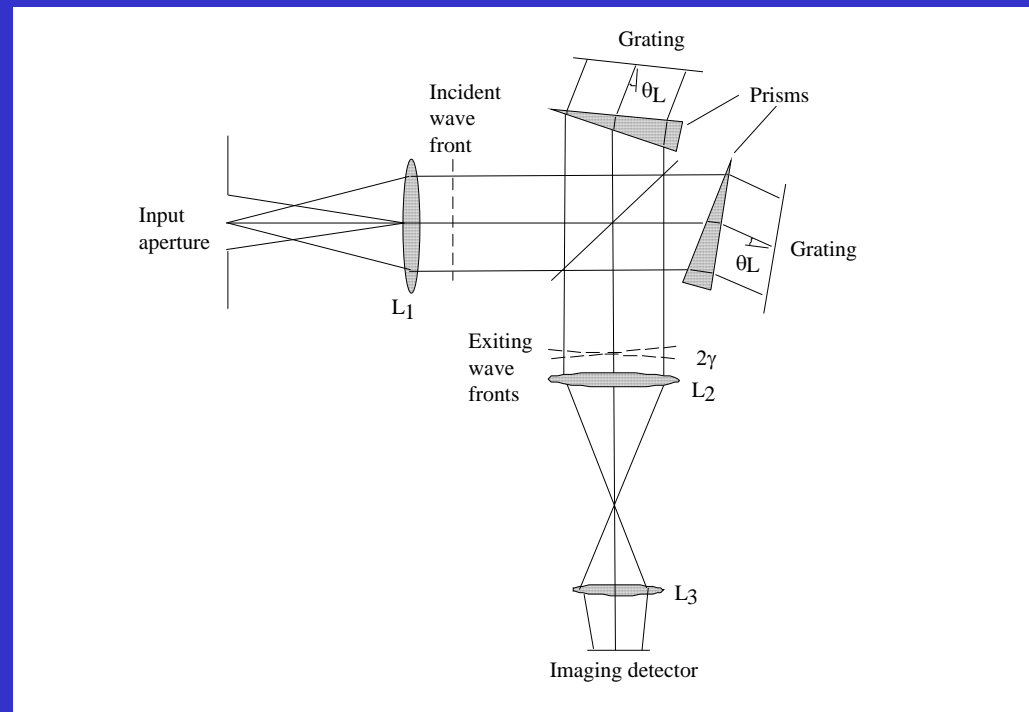

Brassboard Components and its Alignment

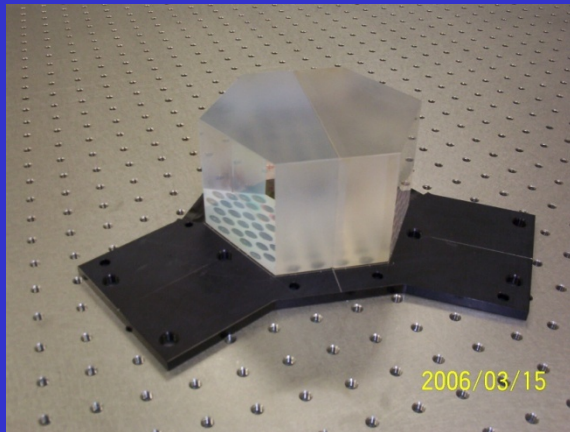

4 Space Science Package (SSP)

Payloads and Data Management

- UV/VIS/NIR spectrometer
- Aurora Imager
- **Space Weather Package (compact virtual Package)**

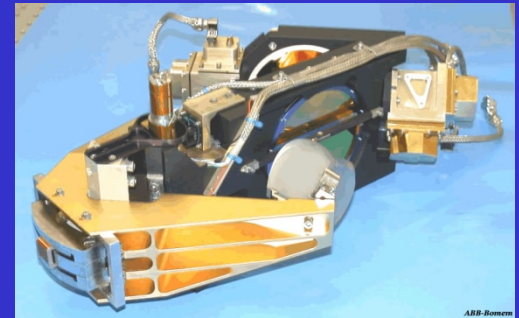

Coordination and conjunction of other observations

Other satellites

Balloon observations (at 30-40km)

UAV (at 10-12km)

Ground observations

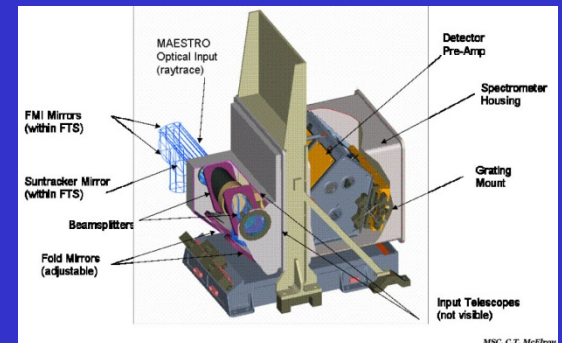

Spacecraft Design and Mission Development and Green House Gases Monitoring from Space

Microtechnology Application

In the early 90's, the advent of the concept of small-sized/microsatellite design provided an alternative approach to significantly decrease costs and enable commercialisation. This breakthrough utilizes alternate spacecraft design methodologies such as scale reduction, repacking/light weighting, microtechnology, high and/or low-level integration and functional design. The keen interest in microtechnology centres mainly on the structuring of macroscopic materials at the micrometer level.

Satellite Orbit

Altitude (km) 600

Circular velocity (km/s) 7,558

orbit Angular velocity (deg/min) 3,723

Escape Velocity (km/s) 10,688 ΔV Req. to deorbit (m/s) -156.7

Sun-Synchronous Inclination (deg) 97.79

Revolutions per day 14.85

Period (min) 96.69

Max Eclipse(MIN) 35.49

The current York spacecraft requirements derived by the payload have led to a three-axis stabilized platform design using only reaction/momentum wheels and magnetorques. The spacecraft design employs components that are to both standard and non-standard. This means that some of the components are readily available on the market while others are currently being space qualified. Radiation shielding of the spacecraft is only applied to the sensitive parts and shall be sufficient to tolerate a 600 km Sun Synchronous Orbit (SSO) for at least 4 years. The spacecraft presented in here is about 55Kg in mass and 60x50x40 cm in volume and 35% of the volume is taken up by the payloads.

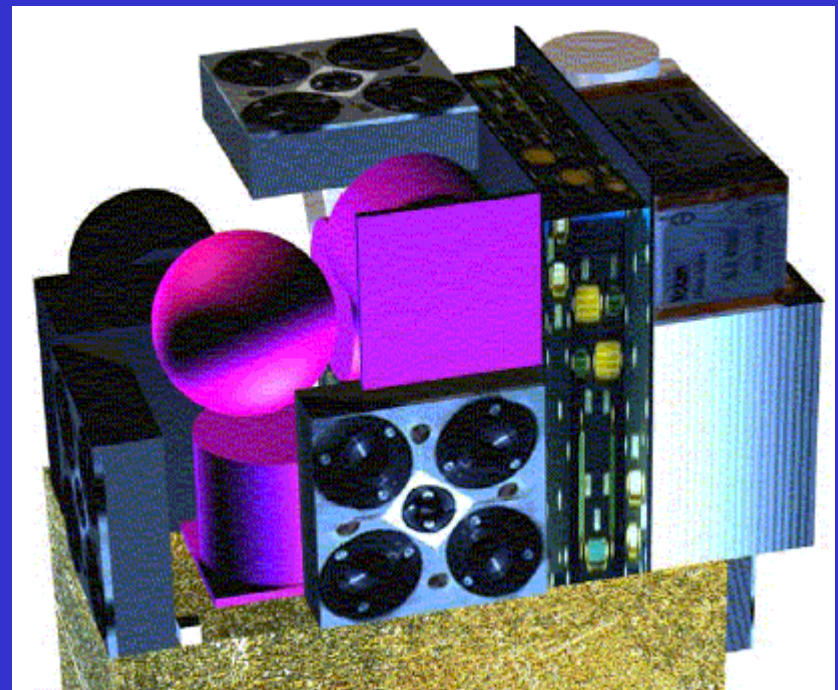

Developing Bluetooth Wireless bus with UTIAS

- Reducing mass and volume of the bus wiring harness
- Higher data transmission rates
- Standardization –use of mature technology and COTS to reduce cost, increase reliability, and decrease development time in the long run.
- Reliability: fault toleration and support for harsh environment of space, launch vibration tolerance
- Plug and play feature, easy removal and addition of nodes
- Low maintenance
- → Optimally leading to schematic design and driver development

Technologies reviewed to date - Wired

- **MIL-STD-1553B:**
 - Serial data bus proposed and maintained by the DoD
 - Data Link layer & Physical Layers of OSI reference model
 - Dual redundancy: 1 in 1 million word error rate
 - Command/response is multiplexed asynchronously
 - Transmission is half-duplex with max 1 Mbits/s
 - Can support up to 31 peripherals

- **CAN Bus:**
 - Serial data bus developed by Robert Bosch GmbH in 1988
 - Data Link layer and the Physical Layers of the OSI reference model.
 - Signal is NRZ encoded at a rate of 1 Mbits/s for up to 40m
 - Message transmission is based on prioritization
 - Automatic retransmission of corrupted data once the bus is free

Technologies reviewed to date - Wired

- **I2C:**
 - Multimaster Serial data bus
 - Data rate upto 3.4Mbits/s.(Max length of bus 3 meters).
 - Does not provide means for error detection

- **Ethernet:**
 - Requires a host controller and has a bus topology
 - Transfer rates upto 1Gbits/s for fast Ethernet.
 - Used for long range high-bandwidth data transmission: equipment is costly and configuration needed
 - Can use TCP/IP and UDP protocols.
 - No power output

Technologies reviewed to date - Wired

- **USB 2.0:**
 - Serial data bus architecture designed in 1996
 - A master-slave architecture, upto 127 devices in a star topology
 - ~480 Mbits/s with NRZI signal encoding
 - Provides 5.0V at 100mA for low power devices.
 - Backward compatible, cheap
 - Supports hot swapping and plug and play
- **Space Wire:**
 - Serial data bus, coordinated by ESA (IEEE1335)
 - A point to point network; 2 differential signal pairs in each direction
 - Low cost, Low power consumption, low EM interference
 - 2-400 Mbits/s → affected by skew and jitter in signal
 - Fault tolerance by routers and cross-switches

Technologies reviewed to date -

Wired

- **FireWire 800 (IEEE1394b):**
 - Serial data bus developed by Apple.
 - Supports multiple hosts per bus
 - Requires non-cyclic bus topology.
 - Data rates of ~786 Mbits/s with better CPU utilization than USB.
 - Supports upto 63 devices,
 - Can bridge buses to provide up to 1024 buses with 63 devices each.
 - Provide up to 45W of power at 30V (no load-unregulated).
 - Easy to add new devices,
 - Features PnP and hot swapping, making the reconfiguration of topology and troubleshooting very simple.
 - Two supported modes of data transfer.
 - Asynchronous mode: obtains a receiver acknowledgement and guarantees data transfer
 - Isochronous mode: guarantees on time data transfer (bandwidth and latency) → real time. Stops receiver from overflowing in case of continuous data.

Technologies reviewed to date - Wireless

- **WiFi:**
 - IEEE802.11g,n,y
 - Serial Data transfer, with mesh topology
 - Depending on type of WLAN uses 2.4,5 or 3.7GHz with max throughput on g being 54 Mbits/s.
 - Security: effective radius of ~35m → encryption, address specific access
 - Increased power consumption (400mA TX and ~40mA standby)
 - PnP and hot swappable
- **Zigbee**
 - IEEE802.15.4
 - PHYS & MAC of DLL in OSI model
 - High level communication Protocol
 - Operates in 2.4 GHz, 915\868 MHz RF bands
 - Low data transfer rates(250 kbits/s, 40kbits/s, 20kbits/s)
 - Lower power (30mA TX, small standby)
 - Security –address specific access, data encryption, frame integrity

Technologies reviewed to date - Wireless

- **Bluetooth**

- IEEE 802.15, A WPAN protocol
- Operation at 2.402-2.480GHz with Frequency Hopping at 1600/s
- Uses GFSK (Gaussian Frequency Shift Key)
- Master-multi slave → piconet
- Connection:
 - Query to find devices
 - Paging (Active mode, Sniff mode, Hold mode, Park Mode)

Class 1	Class 2	Class 3
~100m	~10 m	~10cm
20dB	4dB	0dB

Preliminary Analysis Results

- Optimum wired solution: Firewire
 - Low Power, power output, high speed, plug and play, fault toleration can be implemented
- Optimum wireless solution: Bluetooth
 - Low power, reduce harnessing (mass and volume), high speed, plug and play, secure, radiation tolerant (FHSS)

40s Platform with ARMS

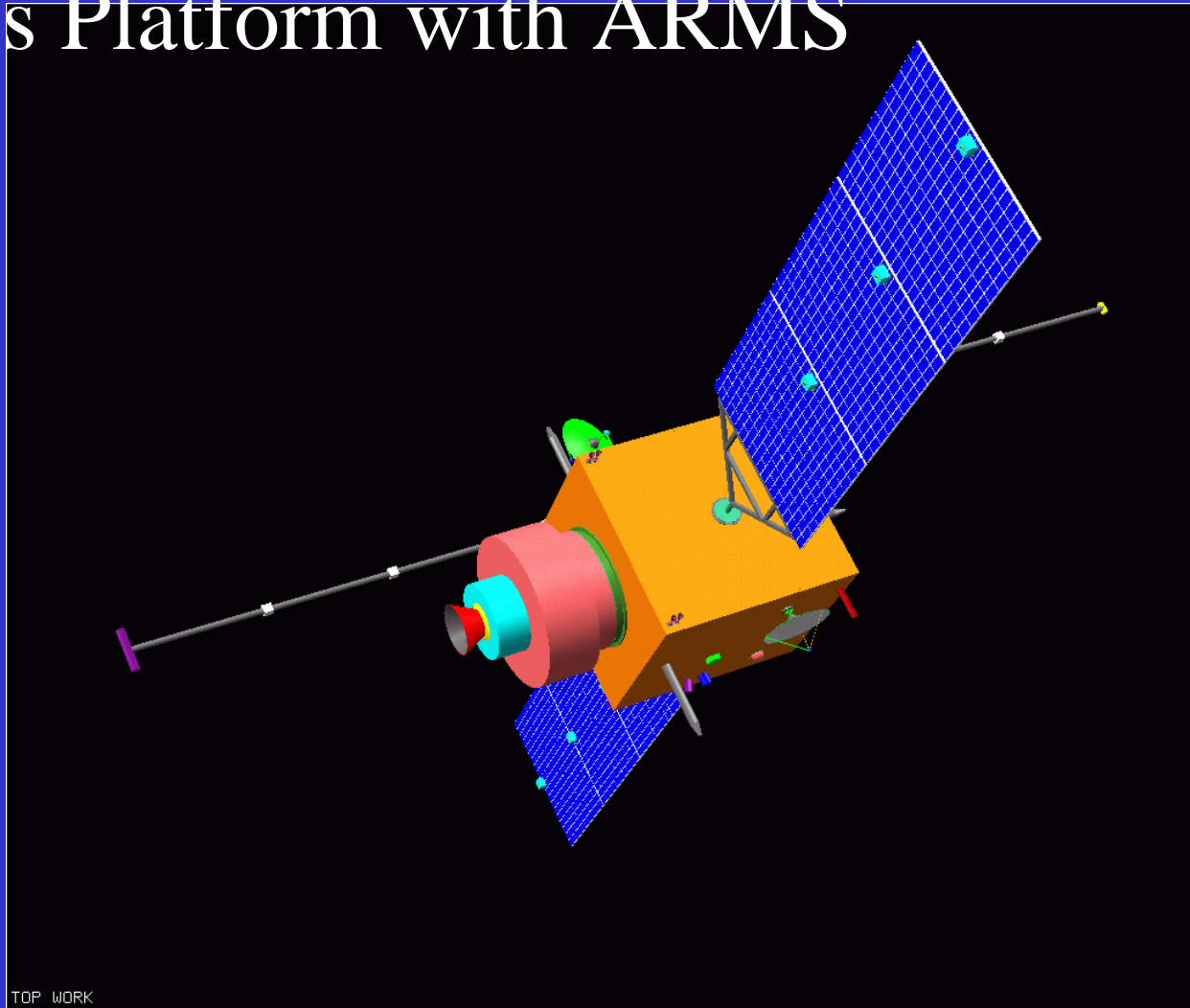

Adapter and Releaser for Multiple Satellites

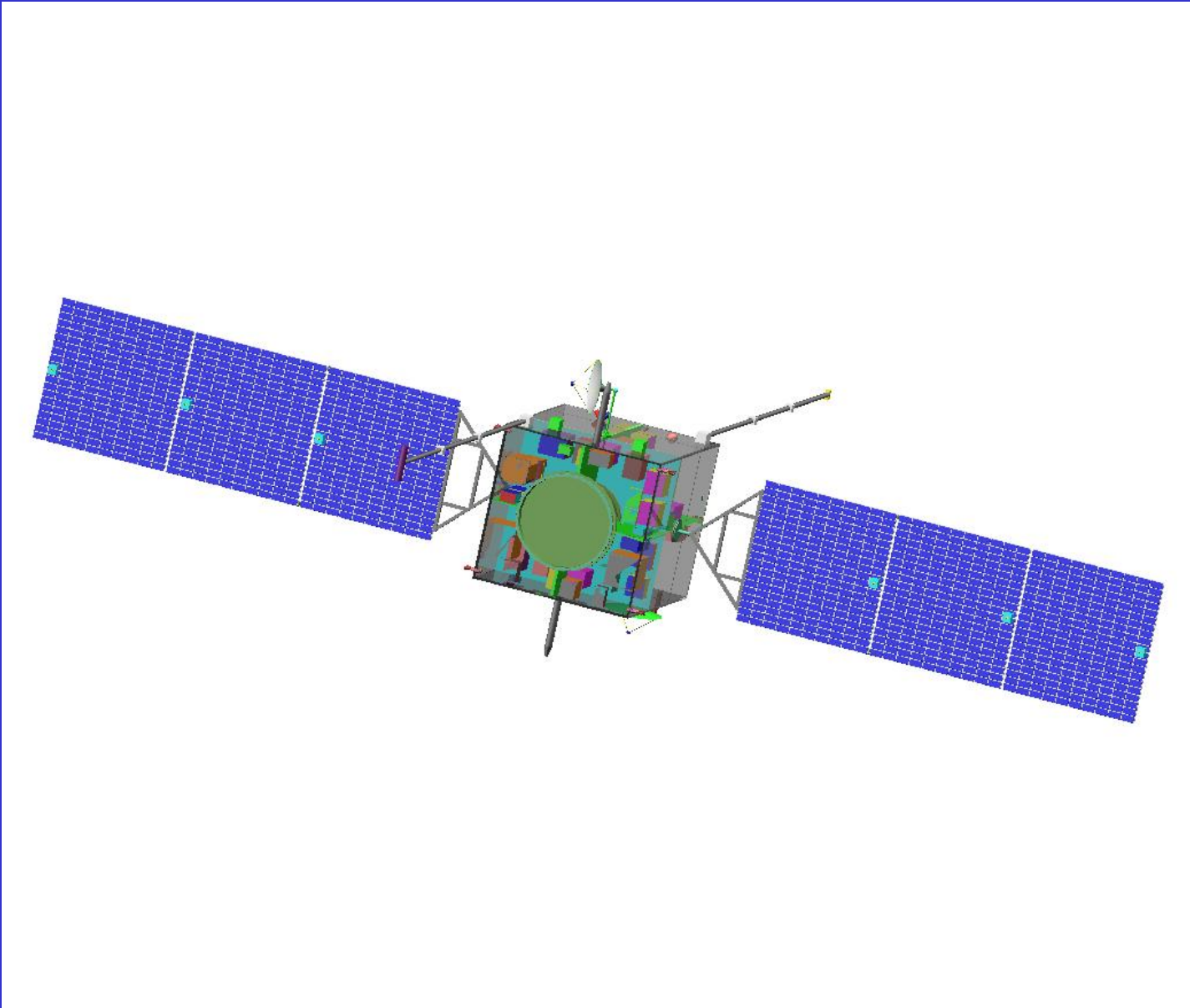

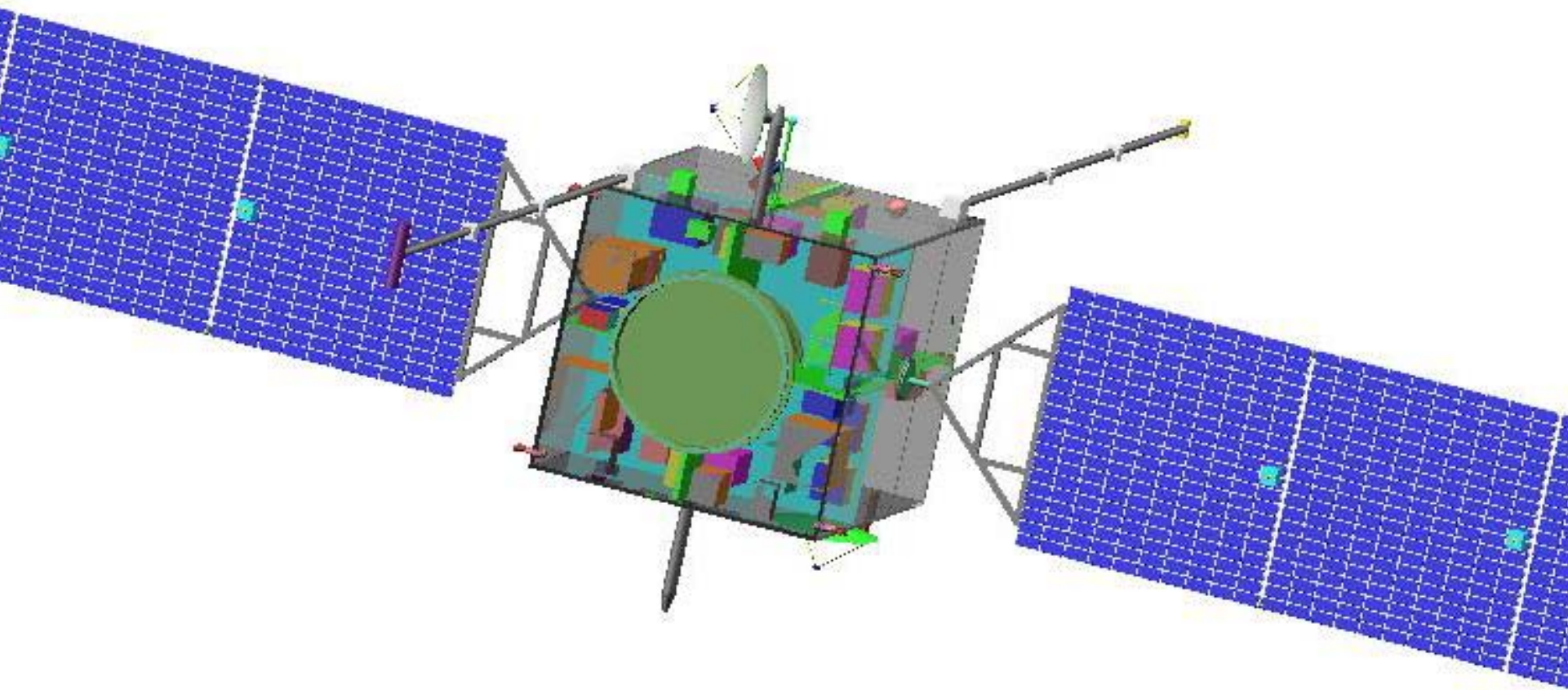

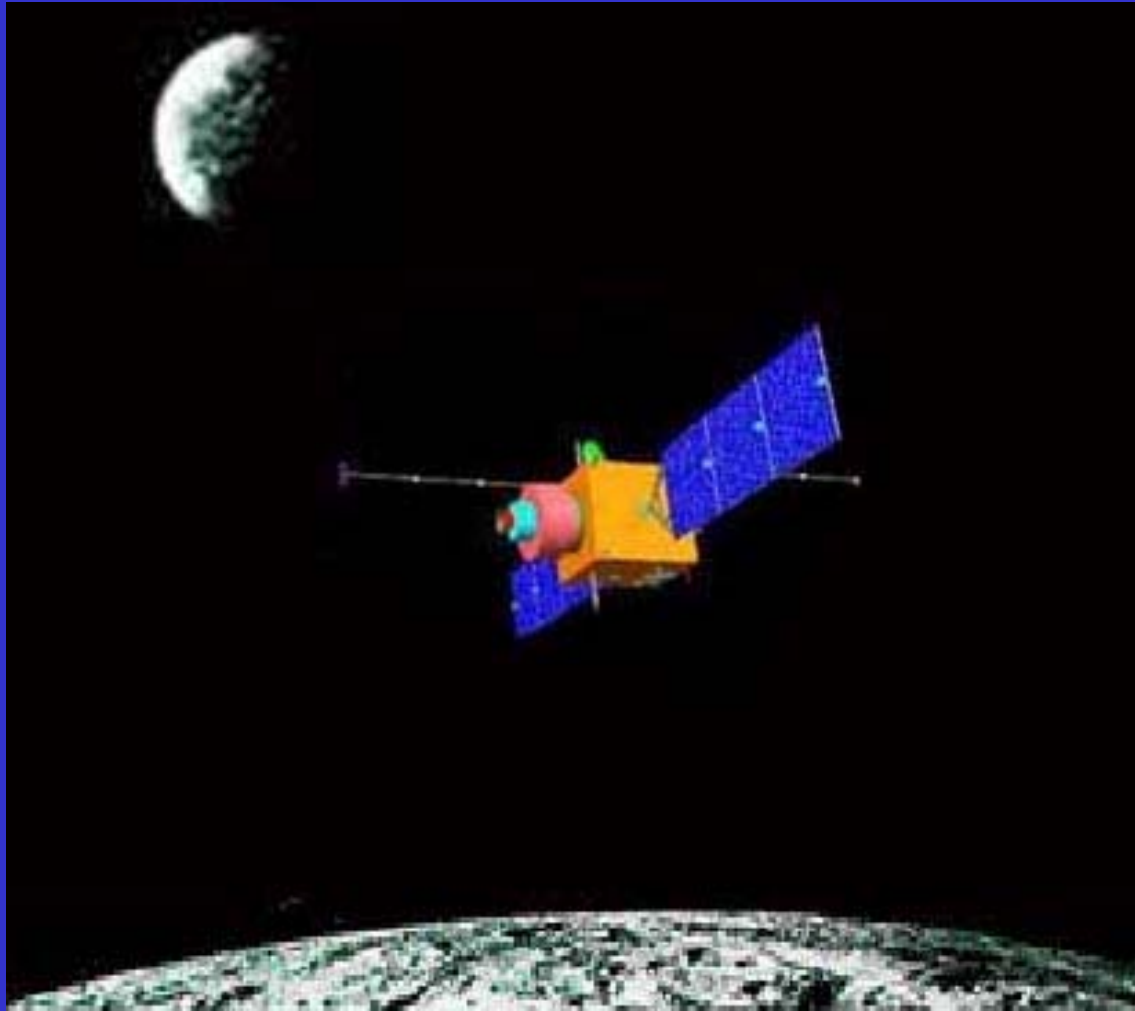

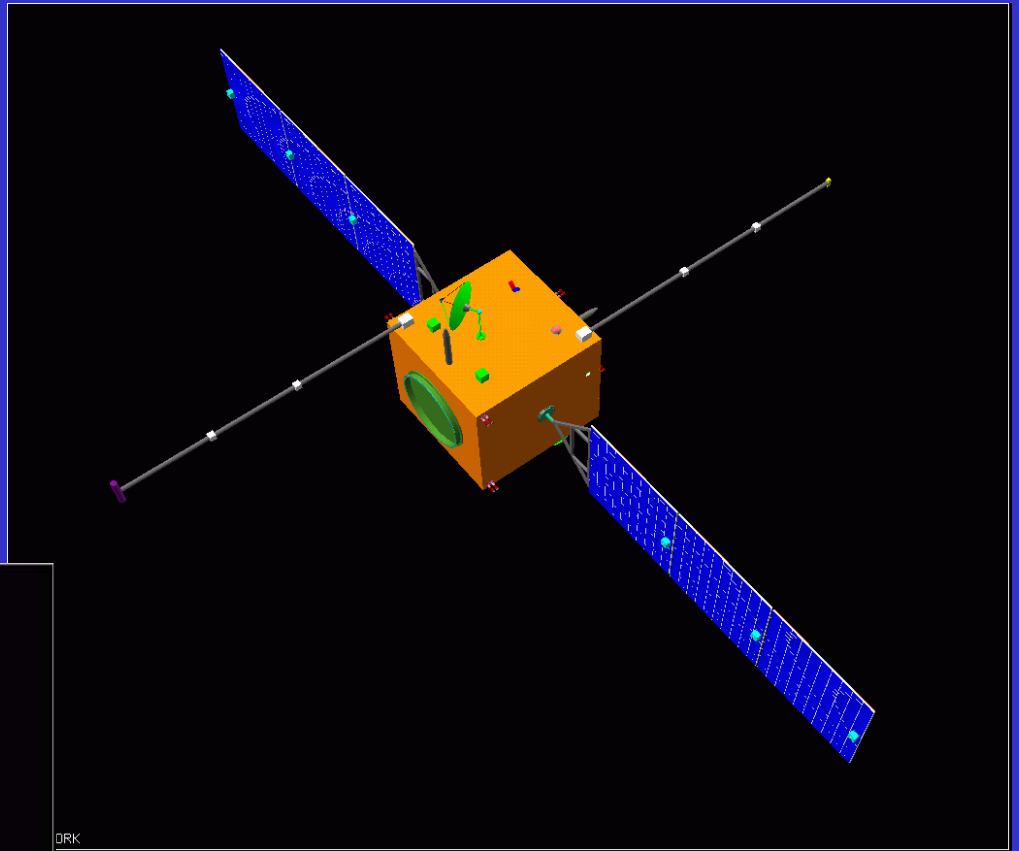

DRK

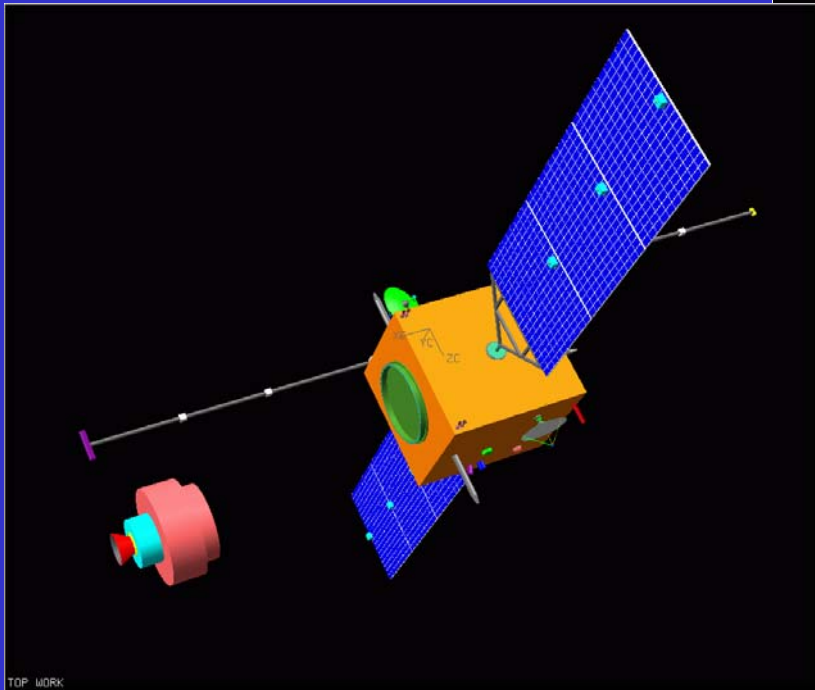

TOP WORK

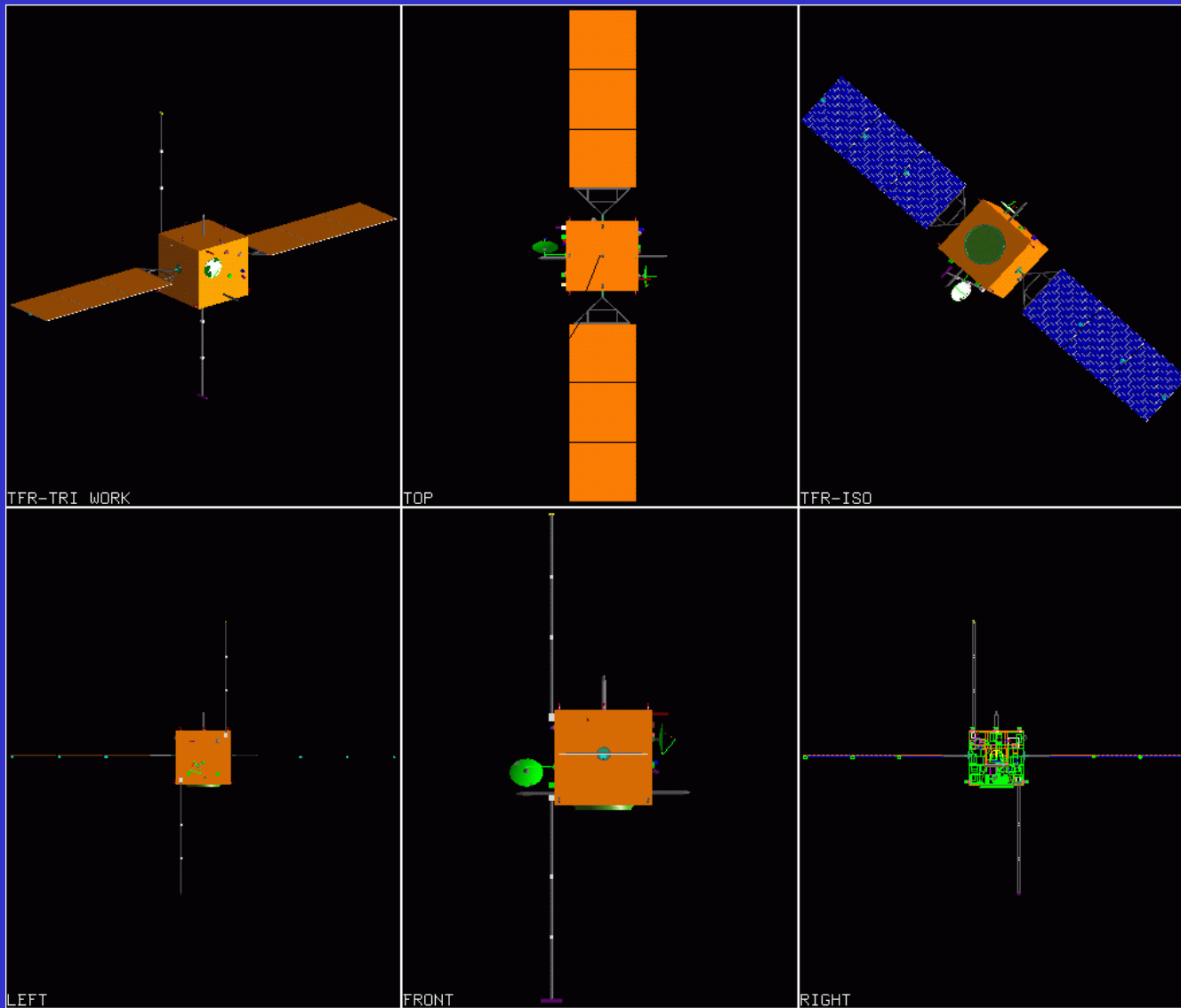

环月卫星六侧视图

Centre for Research in Earth & Space Science (CRESS)

Balloon Platform with Continuum Aerospace

Continuum Aerospace

- float altitude
- float duration
- day-night cycles
- launch/recovery locations
- weather impact of above

York

- Missions of short-term and long term interest
- Instrumentation & its corresponding requirements
- Student flights
- satellite components qualification flights
- Initial technology readiness demonstration flights

Instruments	GRAS	LIMA
Mass	2Kg (including all antenna)	7Kg
Size	NAMURU II board: 11cm x 18cm x 3cm Nadir antenna array: 20cm x 20cm x 4cm Zenith antenna : 9cm in diameter, 3cm high	12cm x 12cm x 15cm
Installation Requirements	Two antenna should be installed on either package wall or balloon surface, in Nadir and Zenith direction, respectively	Each of four channels needs to have its own light tight tube. The baffles would fit in the front 3cm of each tube (although this may be extended a bit).
Pointing Requirements	Two antenna point to Nadir and Zenith direction within 1 degree, respectively	Four input apertures point to roughly 90 degree away from sunlight. More accuracy pointing may be obtained using additional pointing mirror.
Max. Power	10W	16 W
Data Rate	8 ~15Kbps	315Kbps
9Kg 26W		
Total Data and Data Rate	<p>Total Data (for 10 days): 285Gbits in Max. Two 16GB USB flash memories are available for on-board data storage. Data rate: 330Kbps in Max.</p> <p>Mobile Broadband Service from Stratos is available for downlink rate at 32, 64, 128 Kbps, respectively. The Latitude coverage is below 78⁰N. Kiruna is at 67⁰N. There will be about 1 day and 2 days communication available in the mission beginning and the end, respectively. Roughly 10% of total data could be transmitted to ground during the flight.</p>	



2. The requirements to the Flight Package

The requirements derived by the instrument (GPS Receiver for Atmospheric Studies -GRAS, Limb IMaging of Aerosols - LIMA) have led to a request of a stabilized platform design. The flight package design employs components that are to both standard and non-standard. This means that some of the components are readily available on the market while others are currently being flight qualified against temperature, humidity and pressure variations, Electromagnetic interference, shocks and drops.

The flight package presented in here is about 20Kg in mass and 40cm x 40cm x 40 cm in volume and 45% of the mass (9Kg out of 20Kg) is taken up by the instruments.

Engineering Descriptions of the Flight Package

Subsystems	Mass	Power	Size
Instruments	9 Kg	26W	See Instrument Table.
Structure	4 Kg	-	40cm x 40cm x 40cm
Thermal	0.5 Kg	1W	-
Power	1.5 Kg	1W	power unit with four batteries: 8cm x 10cm x 3cm Body mount solar Array (face to sunlight): 38cm x 38cm
On-Board Data Handling	2.5 Kg	4 W	35cm x 30cm
Attitude and Flight Path Determination (GPS)	-	-	-
Communication	2.5 Kg	5 W	Terminal card: 8 cm x 8 cm x 2cm Antenna: Diameter 13cm, thickness 5cm
Total	20 Kg	37W(peak) 30W(a verage) 40W(i nput)	

Mission: 150lb. to 40k ft.



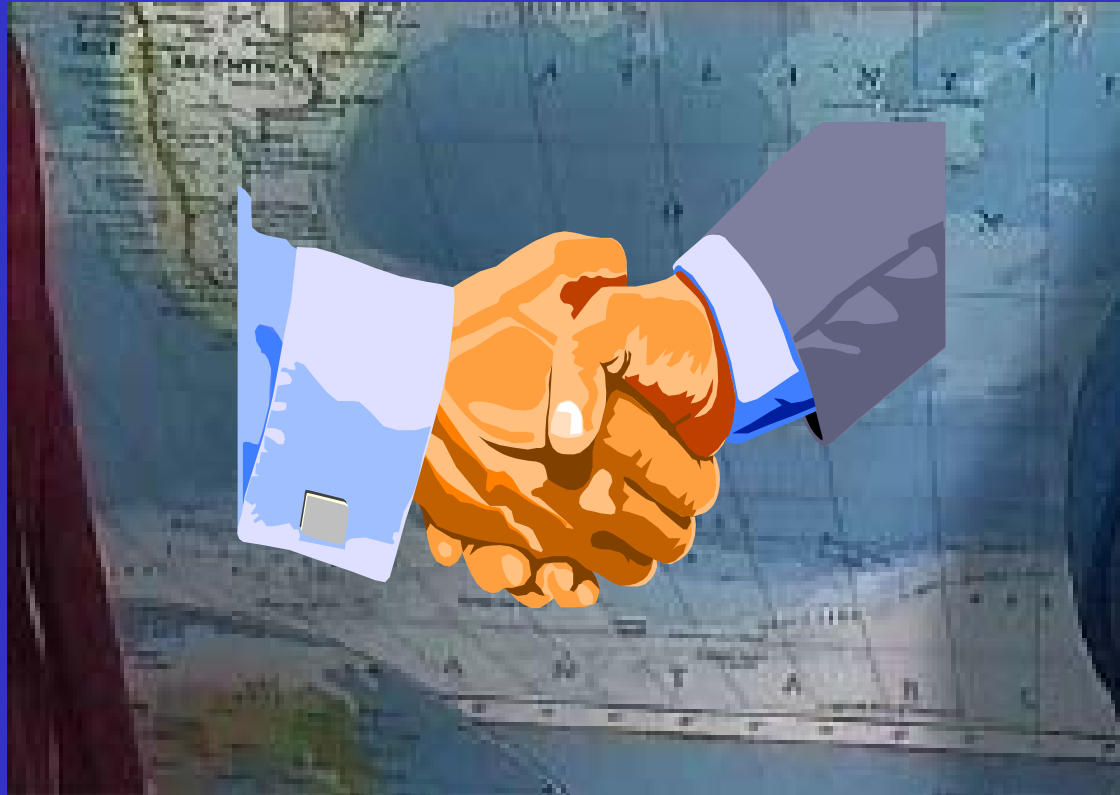

Thank you!